

FRONT

# SFPUC ASSET PROTECTION STANDARDS

Information and Requirements for Proposed Projects in Existing Streets and Public Right-of-Ways



San Francisco  
**Water  
Power  
Sewer**

Services of the San Francisco Public Utilities Commission

## ACKNOWLEDGEMENTS

This Document would not have been possible without the contribution of others. In that regard, the SFPUC appreciates the input provided by the public and a large cross-section of stakeholders including the following City agencies and staff:

San Francisco Public Works

San Francisco Municipal Transportation Agency

San Francisco Planning Department

San Francisco Fire Department

Office of Supervisor Scott Wiener

And other members and agencies of the working groups for the Standards.



Version: May 2017

The San Francisco Public Utilities Commission owns and operates over 1,500 miles of water infrastructure and 1,000 miles of wastewater infrastructure within the limits of the City of San Francisco. Some of this infrastructure dates back to the mid-19th century, yet continues to provide the City with critical utility service. The SFPUC Asset Protection Standards have been implemented to protect the integrity and continued operation of this infrastructure within an ever-changing and complex city environment.



Bay Street at Embarcadero, 1951

# CONTENTS

<b>Message from the General Manager</b> .....	iii
<b>Overview</b> .....	1
Introduction	
Development of the Standards	
Applicability	
How to Use this Document	
Users	
<b>Standard 1 – Paving</b> .....	4
<b>Standard 2 – Sidewalks, Curbs and Gutters</b> .....	6
<b>Standard 3 – Street Profile Changes</b> .....	10
<b>Standard 4 – New Drainage Infrastructure</b> .....	11
<b>Standard 5 – Green Stormwater Infrastructure</b> .....	12
<b>Standard 6 – Vegetation</b> .....	14
<b>Standard 7 – Hydrants</b> .....	16
<b>Standard 8 – Temporary Structures</b> .....	18
<b>Standard 9 – Permanent Structures</b> .....	20
<b>Standard 10 – Underground Utility Clearances</b> .....	24
<b>Project Review</b> .....	26
<b>Variance Process</b> .....	27
<b>Appendices</b>	



Present Day

## MESSAGE FROM THE GENERAL MANAGER

It's my pleasure to sign into effect and issue Asset Protection Standards for the San Francisco Public Utilities Commission (SFPUC). This is a major milestone that evolved from a highly successful collaborative effort to establish safer, greener and more enjoyable streets, while preserving and protecting critical infrastructure.

Over the past two years, the SFPUC met with City agencies and stakeholders to identify and codify standards that protect our existing water and sewer infrastructure in the face of a changing City landscape. As stewards of the built environment, all City agencies share in responsibilities for streetscaping improvements, such as pedestrian and bicyclist safety improvements, public transit initiatives, and beautification projects, to make our streets more accessible, safe and attractive.

Our critical, yet unseen, infrastructure underlying roadways and sidewalks are impacted by these improvement projects, and thus require careful planning. In order to protect the function of our water and sewer infrastructure and provide access for regular maintenance, we have developed these Asset Protection Standards for use by street improvement projects during planning and implementation.

We appreciate your support of these Asset Protection Standards and look forward to working with you and other City stakeholders toward the successful implementation of a multitude of future public right-of-way programs and projects.

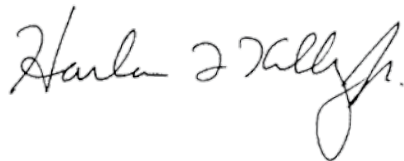

**HARLAN L. KELLY, JR.**  
**GENERAL MANAGER**



## INTRODUCTION

The City of San Francisco (the City) is a dynamic and evolving urban environment. In order to enhance public safety and the streetscape experience, the City is continually working to improve public right-of-ways through programs such as the **Better Streets Plan** and **Complete Streets Policy**. As a City agency, the San Francisco Public Utilities Commission (SFPUC) supports these programs through investments and innovations in water, wastewater, power, and green stormwater infrastructure. In order to continue to best serve the community while complying with the complex regulatory environment as a water and wastewater utility, the SFPUC has developed standards detailed in this document for the protection of the City's existing water and wastewater assets (Standards). The Standards support streetscape innovation while enabling effective and reliable delivery of water and conveyance of stormwater and sewage, while preserving infrastructure functionality and accessibility during planned and emergency operations.

## DEVELOPMENT OF THE STANDARDS

The Standards were originally published as the “SFPUC Wastewater & Water Standards for Surface Improvement Projects” in June 2014. After collaborating with and receiving feedback from a large range of stakeholders, an updated draft version of the Standards (with the revised title “SFPUC Standards for the Protection of Wastewater & Water Assets”) was issued in February 2015. The SFPUC again solicited comments on the updated draft version of the Standards, and the resulting final Standards are presented herein.



# OVERVIEW

## APPLICABILITY

San Francisco Charter section 4.126 authorizes the General Manager to adopt rules and regulations governing matters within the jurisdiction of the San Francisco Public Utilities Commission (SFPUC), subject to subsequent action by the Commission, if any, to modify the General Manager's exercise of such authority. The Standards are necessary regulations that provide guidance to projects in the public right-of-way to protect, maintain the intended function, maintain system performance and level-of-service requirements, and minimize the risk of damage of SFPUC assets while still being accessible for regular and emergency operations and maintenance.

The Standards apply to all projects proposed in a public right-of-way that contains existing SFPUC water and/or wastewater assets. Note other federal, state, and local codes not listed herein may also apply. The Standards do not apply to designs for new or rededicated public right-of-ways which are specifically subject to San Francisco subdivision maps and regulations, which can be found on the ***San Francisco Public Works Webpage***.



## HOW TO USE THIS DOCUMENT

The Standards address ten areas of improvement to public right-of-ways:



1

**PAVING**



2

**SIDEWALKS, CURBS  
AND GUTTERS**



3

**STREET PROFILE  
CHANGES**



4

**NEW DRAINAGE  
INFRASTRUCTURE**



5

**GREEN STORMWATER  
INFRASTRUCTURE**



6

**VEGETATION**



7

**HYDRANTS**



8

**TEMPORARY  
STRUCTURES**



9

**PERMANENT  
STRUCTURES**



10

**UNDERGROUND UTILITY  
CLEARANCES**

Presentation of each standard includes: a brief overview of the context and need for the standard; details on the standard as related to water and wastewater assets; and identification of key outcomes from successful implementation of the standard.

Also included in the Standards is information on the review process for projects potentially impacting water and wastewater assets in the public right-of-way; a description of the related variance review and approval process; and detail drawings accompanying the standards.

During the early stages of improvement project review and permitting, the proposed project will undergo a formal project review by the SFPUC (see **Project Review** on page 26). This process enables the SFPUC to collaborate with the project sponsor to ensure project completion includes appropriate protection of infrastructure assets.

## USERS

The Standards are intended for entities that are proposing improvements to public right-of-ways. Users of the Standards are anticipated to include staff from City departments, designers, planners, developers, and other project sponsors.

# STANDARD 1: PAVING

## OVERVIEW

Paving within public right-of-ways acts not only as a medium for vehicular traffic, but also as a protective barrier for underground utilities. As such, it is important that paving materials installed above SFPUC assets meet applicable loading requirements and are readily available for SFPUC crews and contractors to make street repairs following planned utility replacement projects and emergency utility repair work.

### PROTECTION STANDARDS: WATER

- W1.a** Paving materials installed above or adjacent to water assets shall be approved by San Francisco Public Works (Public Works) - Bureau of Streets and Mapping (BSM) prior to installation.
- W1.b** Paving materials installed above water assets shall meet H-20 traffic loading ratings (as defined by the American Association of State Highway Transportation Officials).
- W1.c** Water valve boxes shall be adjusted to be flush with paving surfaces per *Standard Plan CDD-LP-253* and *CDD-LP-254*.
- W1.d** Paving shall not obstruct or obscure water castings.

WATER



Paving above and around SFPUC assets protects those assets from traffic loads.



## PROTECTION STANDARDS: WASTEWATER

- S1.a** Paving materials installed above or adjacent to wastewater assets shall be approved by Public Works – Bureau of Streets and Mapping (BSM) prior to installation.
- S1.b** Paving materials installed above wastewater assets shall meet H-20 traffic loading ratings (as defined by the American Association of State Highway Transportation Officials).
- S1.c** Paving shall not diminish the overland flow capacity of the street (see **Standard S3** for additional requirements).
- S1.d** Paving shall not obstruct or obscure wastewater castings.



A solid, paved working surface is necessary around manholes to facilitate maintenance work.

## OUTCOMES

When project plans adhere to SFPUC Asset Protection Standards, and Street Encroachment Permits and maintenance agreements that include paving requirements have been issued by BSM, the SFPUC can ensure that:

- Below-ground utilities are protected from potentially damaging vehicle loads, thus protecting public health and safety.
- SFPUC crews and contractors are able to access paving restoration requirements, particularly for non-standard paving materials and features. This allows for expeditious restoration of those surfaces following planned and unplanned utility work, minimizing disruption to the public.
- Non-standard paving does not inhibit SFPUC's ability to open access covers for shutoff valves, manholes, removable access slabs and catchbasins.

# STANDARD 2: SIDEWALKS, SIDEWALK EXTENSIONS, BULB OUTS, CURBS & GUTTERS

## OVERVIEW

Sidewalks, curbs and gutters delineate the boundaries of pedestrian and vehicular traffic, as well as direct and control the flow of stormwater runoff on city streets. Thus, it is important that these facilities are designed not only to meet the goals of the *Better Streets Plan*, but also to ensure the streets' ability to convey runoff, and to maintain access to SFPUC facilities (such as valves, vaults, and manholes).

### PROTECTION STANDARDS: WATER

**W2.a** New curb ramps shall be built in accordance with *Public Works Accessible Street Crossing Standards*, with the following additional conditions:

- i. Curb ramps shall not be constructed in the same location as existing water valves.
- ii. Curb ramp flared sides shall not be constructed in the same location as existing water meter boxes with dimensions greater than ten (10) inches wide by fifteen (15) inches long (1-inch meter box).
- iii. Curb ramp detectable warning areas shall not be constructed in the same location as any existing water utility box.

**W2.b** Curbs and gutters shall not be built in the same location as existing valve boxes and manholes. The lip of any new gutter shall be horizontally offset from the outside edge of any valve box / manhole by a minimum of six (6) inches. The face of any new curb shall be horizontally offset from the outside edge of a valve box / manhole by a minimum of eighteen (18) inches. See *Detail APS WS2.1*.



Properly designed bulb-outs and sidewalk extensions enhance pedestrian safety while providing continued access to hydrants and other assets for operation and maintenance.



## STANDARD 2: SIDEWALKS, SIDEWALK EXTENSIONS, BULB OUTS, CURBS & GUTTERS

### WATER

#### **W2.c** Sidewalk encroachment over potable/recycled water assets (*Detail APS W2.2*):

- i. Sidewalk and bulb outs longer than one hundred thirty (130) feet, as measured in *Detail APS W2.2*, shall only be allowed to extend over potable recycled water mains when approved in writing by SFPUC-CDD.
- ii. Sidewalk extensions may extend over potable/recycled water lateral service valves, provided the following conditions are satisfied:
  - The valve box shall be replaced per *Standard Plan CDD-LP-254*.
  - A clear path of travel a minimum of four (4) feet wide shall be provided for CDD and SFFD staff between the street and the valve as shown in *Detail APS W2.2*.
- iii. Sidewalk extensions shall not extend over or around potable/recycled water main valves that are in the street under existing conditions. Main valves shall be accessible at all times by CDD and SFFD emergency vehicles.

#### **W2.d** Sidewalk encroachment over AWSS assets (*Detail APS W2.3*):

- i. Sidewalk and bulb outs longer than one hundred thirty (130) feet, as measured in *Detail APS W2.3*, shall not extend over AWSS mains.
- ii. Sidewalk extensions shall not extend over AWSS valves that are in the street under existing conditions. All AWSS valves need to be accessible at all times by CDD and SFFD emergency vehicles.

#### **W2.e** Pedestrian boarding islands and street medians constructed per *Public Works Standard Plan File 87,172* shall be considered sidewalks.



Clear space around water valves is necessary to access, operate, and maintain the valves.

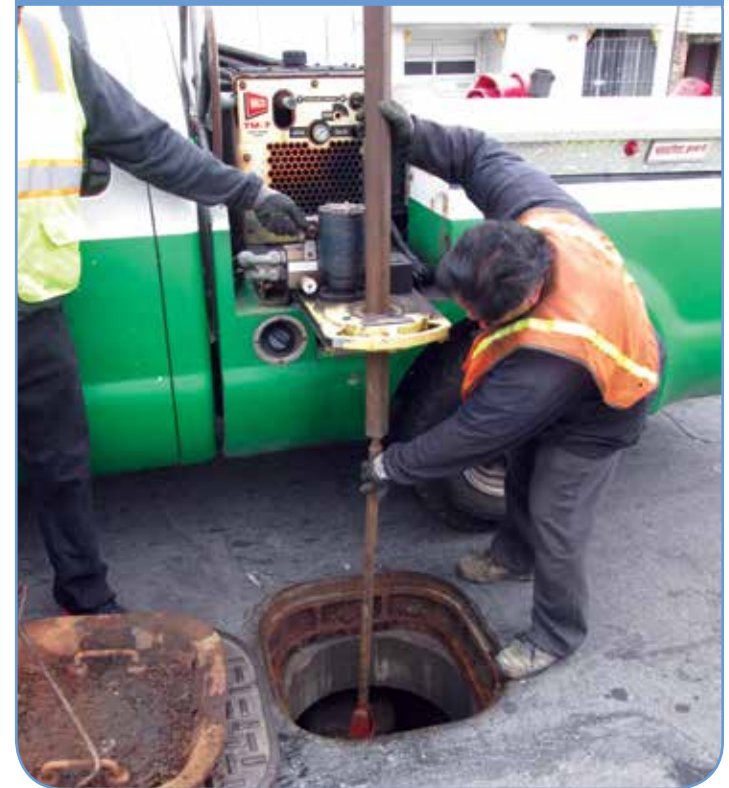

# STANDARD 2: SIDEWALKS, SIDEWALK EXTENSIONS, BULB OUTS, CURBS & GUTTERS

## PROTECTION STANDARDS: WASTEWATER

- S2.a** Sidewalk extensions, bulbouts, curbs and gutters shall not be built in the same location as existing manholes. The lip of any new gutter shall be horizontally offset from the outside edge of any manhole frame by a minimum of six (6) inches. The face of any new curb shall be horizontally offset from the outside edge of any manhole frame by a minimum of eighteen (18) inches. (*Detail APS WS2.1*)
- S2.b** If a project results in a manhole located outside of a vehicular path of travel, unobstructed vehicular access with H-20 traffic loading shall be provided within ten (10) horizontal feet of the manhole.
- S2.c** Projects that result in modifications to subsurface drainage infrastructure must maintain a straight culvert connection from all catch basins or drain inlets to a manhole; bends in the culvert connection between the catch basin and manhole are not permitted.
- S2.d** Sewer Laterals:
- Positive surface slope shall be maintained from all sewer lateral air vents to the gutter. (*Detail APS S2.4*)
  - Pedestrian path-of-travel shall avoid the flow path for sewage resulting from a sewer lateral air vent back-up.
  - When sidewalks are extended into the street, the center of the sewer lateral air vent and trap must be relocated such that the trap fitting terminates at the face of the curb. See *Detail APS S2.4* and *Public Works Standard Plan File 87,196*.
  - Sewer laterals shall meet requirements outlined in the *SFPUC Sewer Lateral Standard Details and Specifications*.
- S2.e** Pedestrian boarding islands constructed per *Public Works Standard Plan File 87,172* shall be considered sidewalks.

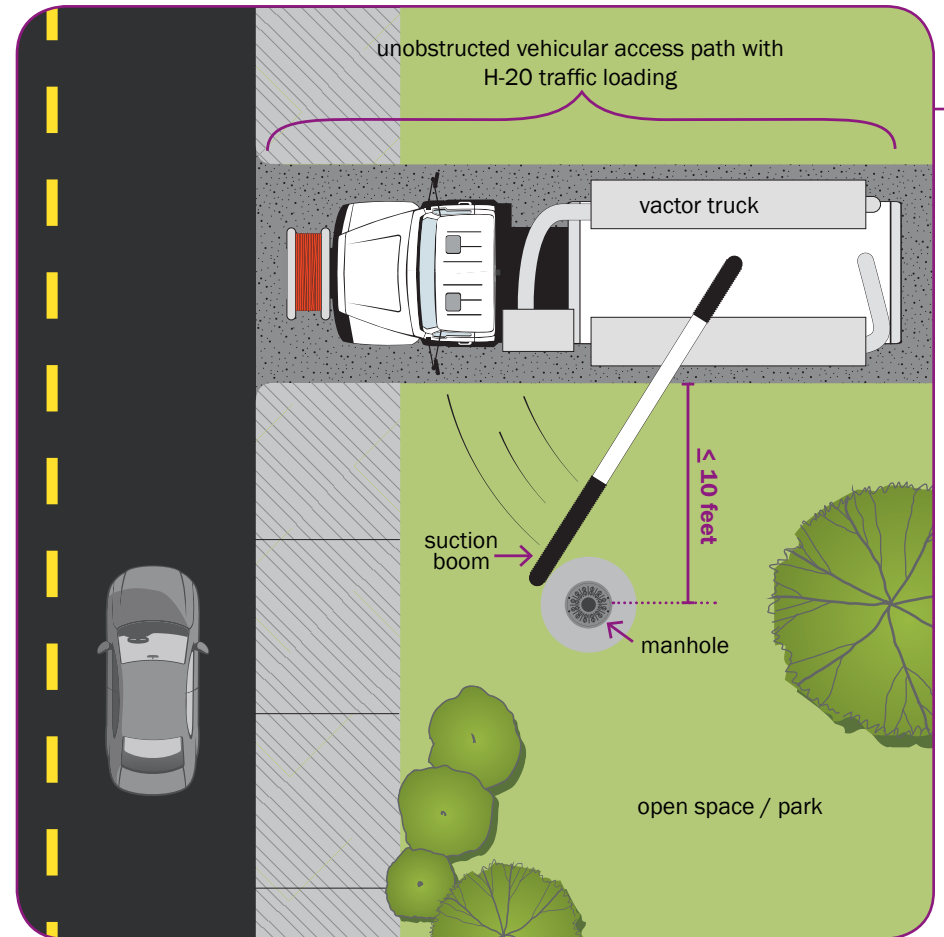

## STANDARD 2: SIDEWALKS, SIDEWALK EXTENSIONS, BULB OUTS, CURBS & GUTTERS

### OUTCOMES

Adherence to the SFPUC Standards ensures that SFPUC staff will be able to quickly access and operate underground water and wastewater utilities when required for planned or emergency repair projects. More specifically, these standards ensure:

- Curb ramps are compliant with the Americans with Disabilities Act (ADA) and safe for pedestrians.
- Pedestrians are protected from tripping hazards posed by at- and above-grade SFPUC utility access points.
- Clear space around manholes and valve boxes is maintained so SFPUC crews can properly open and laydown valve covers and heavy manhole lids, and safely operate the facilities within.
- SFPUC utility access points are accessible by heavy equipment.
- Valve boxes remain plumb with valve operating nuts, allowing for continued proper operation.
- Sewer backups are kept outside of the pedestrian path of travel to minimize tripping hazards and exposure to sewer excursions.
- Overland runoff properly flows to the SFPUC combined sewer system and system performance is optimized.



A paved working surface is needed around wastewater manholes to facilitate access to the wastewater collection system for routine inspection and maintenance.

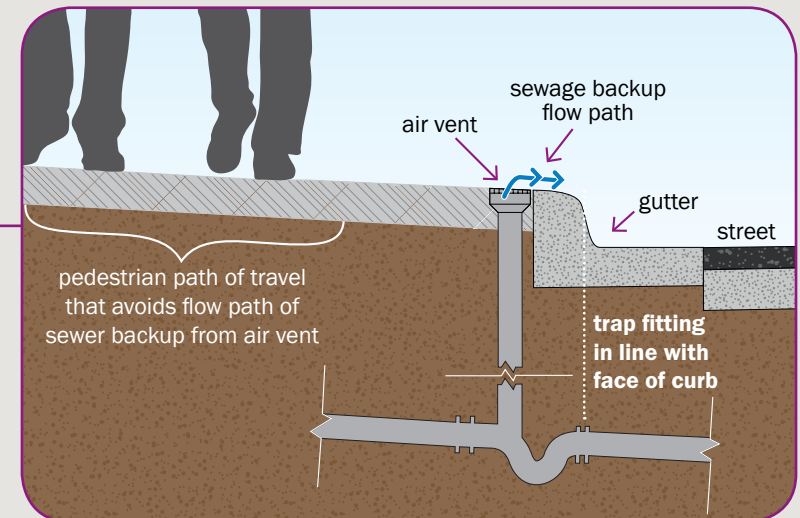

# STANDARD 3: STREET PROFILE CHANGES

## OVERVIEW

The curb, gutter and street surface provide an essential drainage function during storms. Changes to the profile or addition of other surface features in right-of-ways and easements may necessitate additional project elements that maintain or improve drainage and/or overland flow. It is important that designers consider the effects of proposed street improvements on stormwater flow and drainage, and appropriately mitigate designs to minimize the risk of flooding, protect public health and safety, and maintain or improve system performance.

### WATER

#### PROTECTION STANDARDS: WATER

**W3.a** Changes to the profile of right-of-ways and/or easements above water assets may necessitate the adjustment, relocation, and/or replacement of those facilities. The minimum and maximum cover outlined in *Detail APS WS3.1* shall be maintained.

### WASTEWATER

#### PROTECTION STANDARDS: WASTEWATER

**S3.a** Changes to the profile of right-of-ways and/or easements above wastewater assets may necessitate the adjustment, relocation, and/or replacement of those facilities. The minimum and maximum cover outlined in *Detail APS WS3.1* shall be maintained.

**S3.b** Projects that may alter drainage and/or overland flow management capacity of the street shall be screened by SFPUC.

**S3.c** Projects identified through screening to impact drainage and/or overland flow management shall:

- i. Fund a hydraulic analysis of the impact and appropriate mitigation of the project by incorporating recommended project elements to maintain drainage to the collection system.
- ii. Incorporate recommended project elements to maintain or improve the street's capacity for overland flow management of stormwater at the pre-project level or better. SFPUC may evaluate additional project elements to improve drainage and/or overland flow.



The street profile is designed in part to convey stormwater to collection points, such as bioretention planters and catch basins. Changes to the street profile can cause inadvertent and detrimental impacts related to runoff and flooding.

## OUTCOMES

When designed and constructed properly, projects that change the street profile, such as curb extensions, medians, modified street grades, and raised crosswalks or cycle tracks should enhance the streetscape and public safety without deleterious effects of potential flooding and infrastructure damage. Specifically:

- The ability of a street to accommodate stormwater flows and system performance is maintained or improved.
- Underground SFPUC assets are protected from impacts from heavy vehicle loads (that may otherwise occur if a project reduces the required amount of cover above buried utility assets).

# STANDARD 4: NEW DRAINAGE INFRASTRUCTURE

## OVERVIEW

Drain connections to catch basins or stormwater inlets can exacerbate localized ponding, cause upstream flooding or backups, introduce sewer odors, and increase future catch basin relocation costs. Please note, this section does not apply to water assets.

WASTEWATER

### PROTECTION STANDARDS: WASTEWATER

- S4.a** New drains are not permitted to connect to the back of a catch basin or stormwater inlet.
- S4.b** All new catch basins shall connect directly to a manhole or sewer main larger than forty-two (42) inches in diameter or three (3) feet by five (5) feet in size via a culvert. Catch basins are not permitted to be connected to one another prior to connection to a manhole or sewer main.
- S4.c** Trench and railway track drains shall be connected to a sand trap device prior to connection to the SFPUC wastewater collection system.

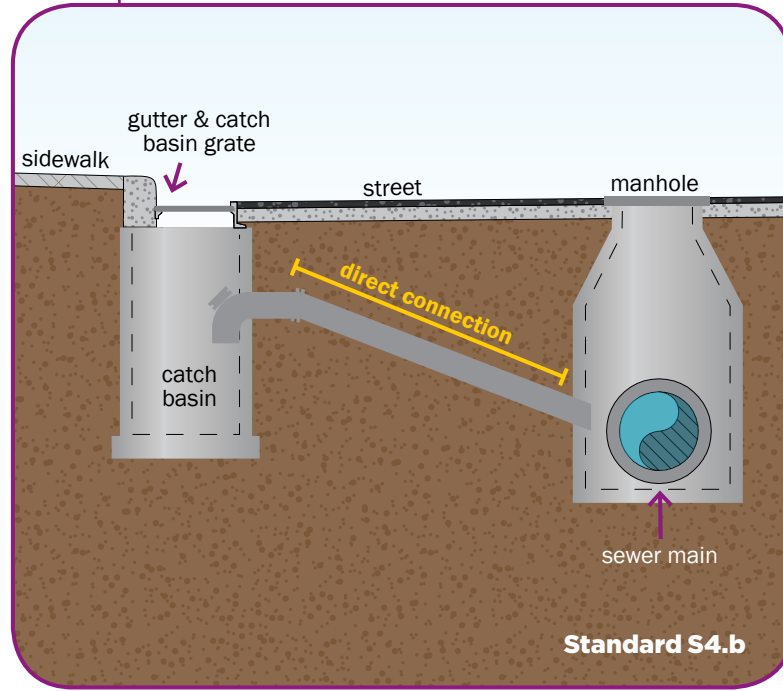
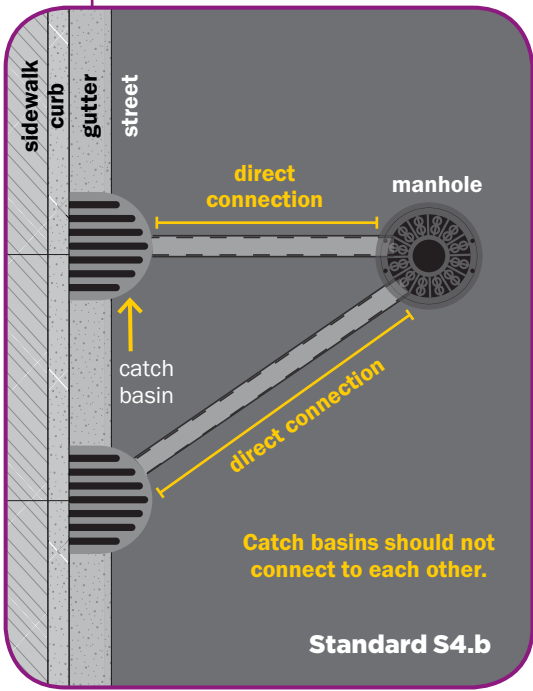

### OUTCOMES

Preventing ponding and flooding is necessary in order to preserve public health and safety because ponding and flooding may cause sewage backup and blockage of streets. When new drainage infrastructure is constructed appropriately, sidewalks and streets are drained effectively, thus minimizing potential ponding and flooding.

# STANDARD 5: GREEN STORMWATER INFRASTRUCTURE

## OVERVIEW

Green stormwater infrastructure can provide peak flow volume control and treatment of stormwater runoff by providing stormwater storage, infiltration into native soil, and/or filtration. The SFPUC encourages the inclusion of green infrastructure into surface improvement projects when appropriate for the site to reduce stormwater flow to the sewer system. However, green infrastructure above and directly adjacent to other water and wastewater infrastructure can impede SFPUC access to these assets in the case of operation, maintenance, and repair or replacement activities.

WATER

### PROTECTION STANDARDS: WATER

- W5.a** Bioretention planters and permeable pavement edge treatments are not permitted above or within three (3) horizontal feet of the outside diameter of a water main or valve box / manhole.
- W5.b** The footprint of bioretention planters are not permitted to contain operable water surface facilities and service points (including but not limited to water valves, meter boxes, and manholes).
- W5.c** Projects that install bioretention planters or permeable pavement in the parking lane above potable water service laterals shall protect the water service laterals through the entire width of the planter or permeable pavement as per the **SFPUC Green Infrastructure Typical Details, Phase II**.

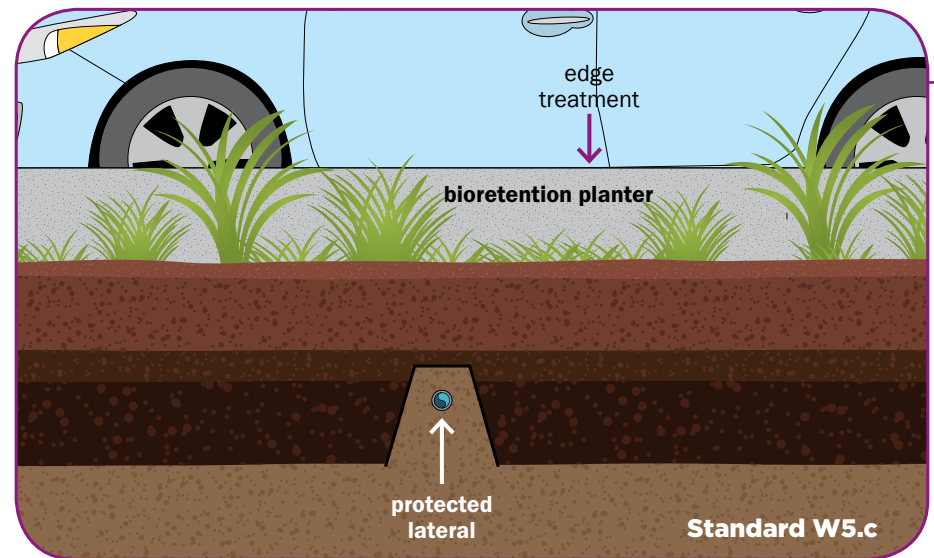
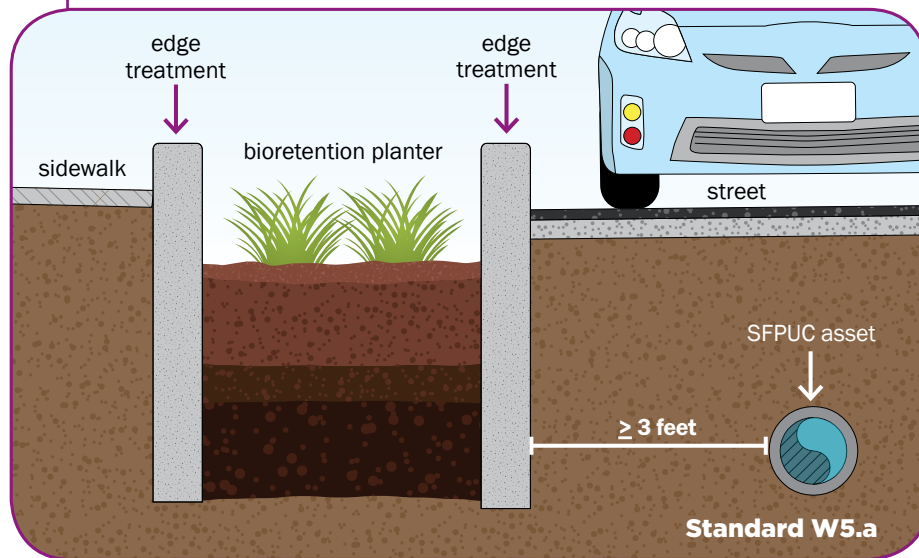



## STANDARD 5: GREEN STORMWATER INFRASTRUCTURE

### WASTEWATER

#### PROTECTION STANDARDS: WASTEWATER

- S5.a** Bioretention planters and permeable pavement edge treatments are not permitted above or within three (3) horizontal feet of the outside diameter of a sewer main or manhole cover frame.
- S5.b** Projects are not permitted to modify the drainage management area, size, or material of existing SFPUC green infrastructure assets.
- S5.c** Sewer Laterals
- i. Projects that install bioretention planters or permeable pavement in the parking lane above sewer laterals shall protect the sewer lateral through the entire width of the planter or permeable pavement as per the ***SFPUC Green Infrastructure Typical Details, Phase II***.
  - ii. Sewer laterals shall meet requirements outlined in the ***SFPUC Sewer Lateral Standard Details and Specifications***.



Typical Green Stormwater Infrastructure bioretention planter

#### OUTCOMES

Proper design and construction of green infrastructure projects enhances stormwater management and quality and provides aesthetic benefits to the public while also protecting and allowing operation and maintenance of below-ground utilities. The Standards ensure:

- The continued structural integrity and functioning of subsurface infrastructure, such as potable water laterals.
- Adequate clearance between green infrastructure and other subsurface utilities, ensuring SFPUC crews can access those utilities for required maintenance with minimum public disruption.
- Existing green infrastructure will continue to effectively collect and treat stormwater.

# STANDARD 6: VEGETATION

## OVERVIEW

Vegetation above and directly adjacent to water and wastewater assets blocks SFPUC access to these assets in the case of future maintenance, repair, or replacement activities. Project proponents should be mindful of existing utilities when planning and installing vegetation within public right-of-ways or utility easements.

### PROTECTION STANDARDS: WATER

**W6.a** Trees shall not be located within five (5) horizontal feet of a water asset, from the centerline of the tree to the outside edge of the asset.

**W6.b** Non-tree vegetation is permitted above or adjacent to water assets, provided the following conditions are met:

- i. Planted areas shall not be constructed around existing water valves.
- ii. Planted areas shall not be constructed around existing water meter boxes and vaults greater than twenty (20) inches wide by thirty-three (33) inches long (2-inch meter box).
- iii. The planted area shall not contain vegetation that may obstruct or overgrow meter boxes.
- iv. The planted area shall not include vegetation containing thorns.

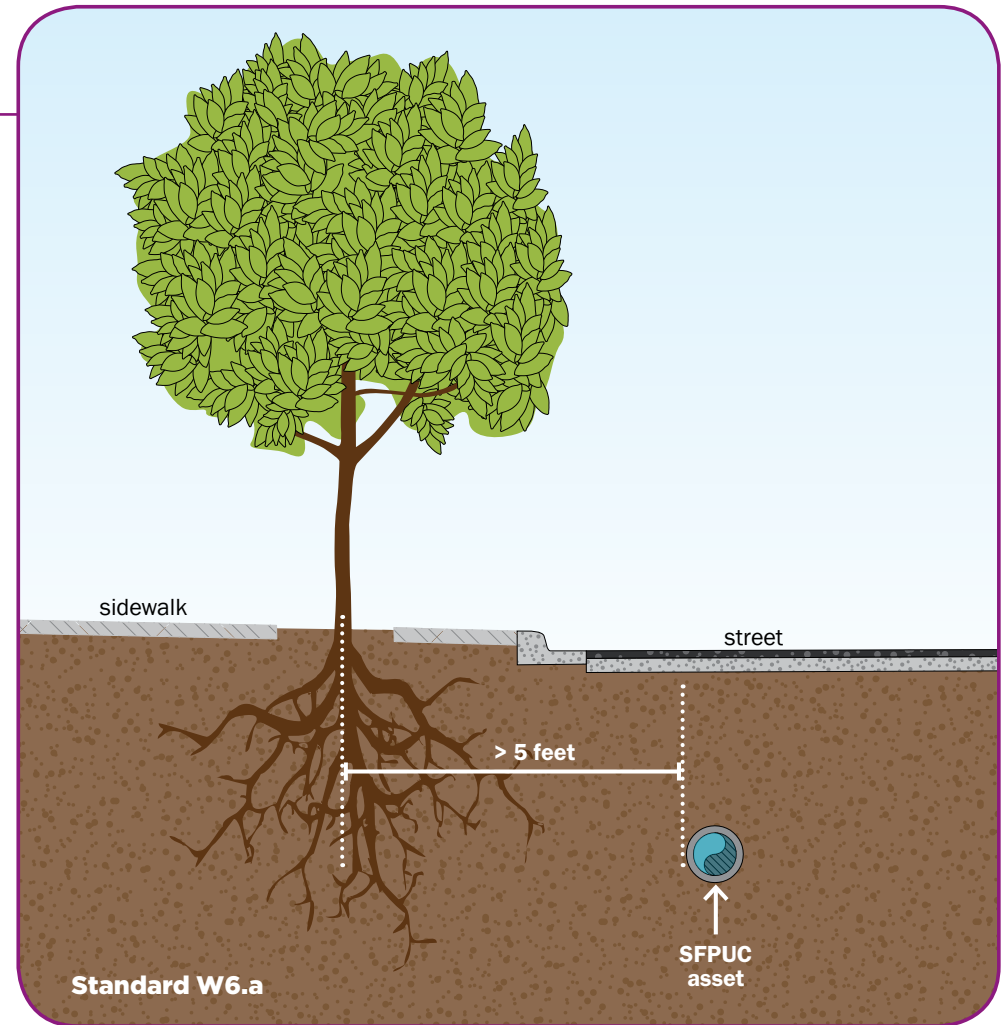

### PROTECTION STANDARDS: WASTEWATER

- S6.a** Trees shall not be located within five (5) horizontal feet of a wastewater asset, from the centerline of the tree to the outside edge of the asset.
- S6.b** Non-tree vegetation is permitted above or adjacent to wastewater assets.
- S6.c** If the project results in a manhole(s) located in a planted area, the project shall include a minimum eighteen (18) inch wide reinforced concrete collar around the manhole(s).
- S6.d** Sewer Laterals
  - i.** Projects that result in a lateral air vent(s) located in a planted area shall either retain the existing paving within six (6) inches of the lateral air vent(s) or include a new concrete pad.
  - ii.** Sewer laterals shall meet requirements outlined in the *SFPUC Sewer Lateral Standard Details and Specifications*.

### OUTCOMES

Adherence to the Standards promotes protection of both vegetation and underground infrastructure from damage. Specifically, the Standards ensure:

- Assets in otherwise good condition are protected from tree roots which may push and shift assets over time, leading to cracks or breaks in the assets.
- Enhanced protection of trees from damage or removal during required utility maintenance.
- Retained integrity and accessibility of utility access points such as valve boxes, meter boxes, vaults, sewer vents and manholes.



Water service installation in planter area with no trees

# STANDARD 7: HYDRANTS

## OVERVIEW

Hydrants are located throughout the City so that the Fire Department can fight fires and protect the lives and property of the people of San Francisco. Hydrants must be readily accessible by the Fire Department and SFPUC staff during emergencies and for regular planned maintenance.

### WATER

#### PROTECTION STANDARDS: WATER

**W7.a** Changes to right-of-ways shall not encroach on the San Francisco Fire Department and San Francisco Water Department operational clearance requirements presented in *Detail APS W7.1* and *Detail APS W7.2*.

### WASTEWATER

#### PROTECTION STANDARDS: WASTEWATER

**S7.a** Fire hydrants shall be a minimum of three (3) horizontal feet away from wastewater assets (including sewer lateral and sewer lateral air vents), and shall not block SFPUC access to wastewater assets.



Ensuring hydrants remain visible and accessible from the street allows the San Francisco Fire Department to expeditiously respond to fires when hydrants are needed.

## OUTCOMES

Fire hydrants are essential in protecting the public in case of fire emergencies. Maintaining appropriate operational clearances as described in the Standards ensures:

- SFPUC staff can use required trucks and equipment to maintain and replace fire hydrants and ensure that all hydrants within the City are operable and ready for fire-suppression service.
- San Francisco Fire Department Firefighters can quickly access and use fire hydrants during emergencies.
- SFPUC staff have ongoing access to water and wastewater assets that adjoin hydrants and fire-suppression water systems.



# STANDARD 8: TEMPORARY STRUCTURES

## OVERVIEW

Temporary improvements above water and wastewater assets may damage water and wastewater assets, impede the flow of surface water to the sewer, or limit access for routine or emergency maintenance, repair or replacement. With this in mind, it is important that temporary structures maintain minimum clearances from SFPUC assets per the standards below.

### PROTECTION STANDARDS: WATER

**W8.a** Owners of temporary structures shall remove and/or relocate temporary structures as required for the SFPUC to perform scheduled repair and maintenance of water assets.

**W8.b** Temporary improvements shall not be placed above water meter boxes, vaults or other surface access points to water assets.

- i. Temporary structures shall not encroach on the water valve operational space required for valve operation as presented in *Detail APS W8.1*.
- ii. Temporary structures shall be a minimum of eighteen (18) inches from the outside edge of any water service meter box or vault.

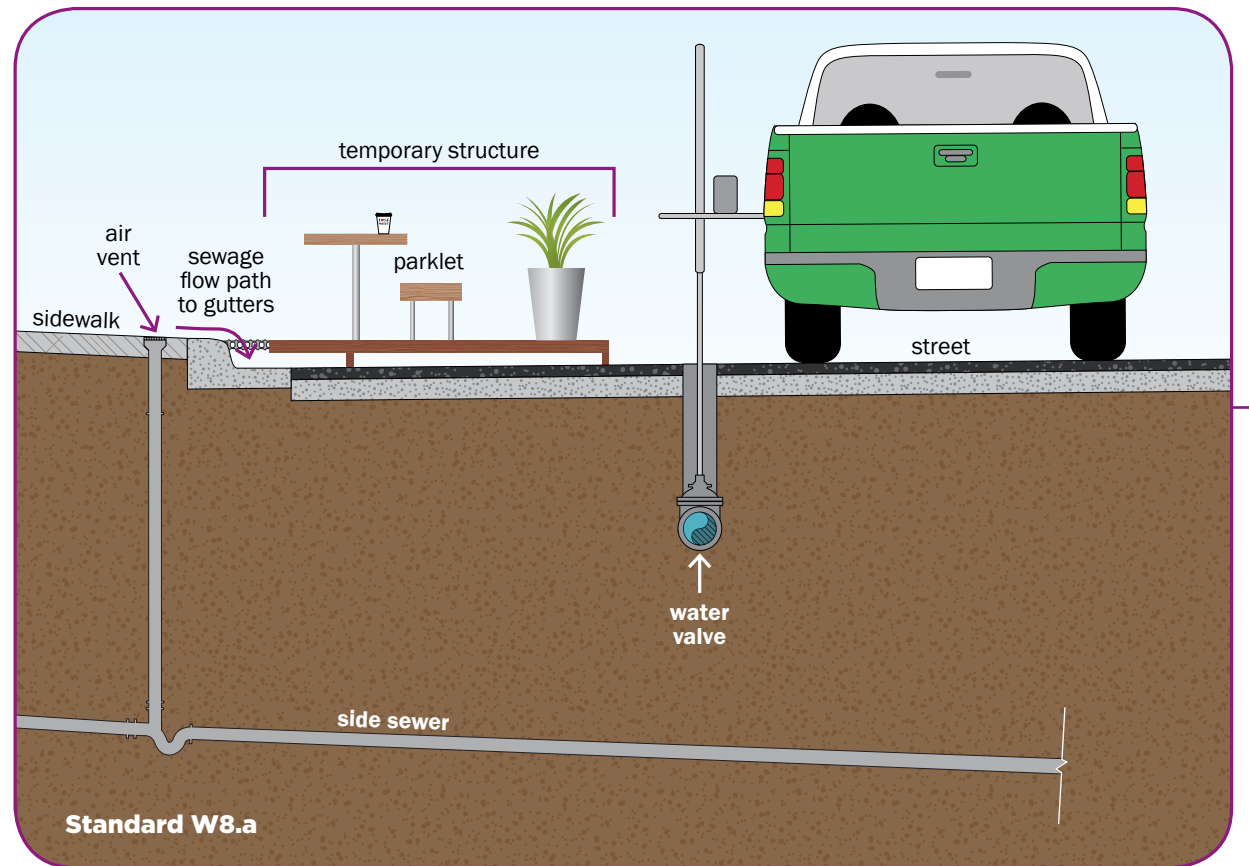

## STANDARD 8: TEMPORARY STRUCTURES

### PROTECTION STANDARDS: WASTEWATER

- S8.a** Temporary Structures above wastewater assets shall not exceed loads defined in H-20 design criteria.
- S8.b** Temporary structures shall not impede the curbside flow of drainage during a storm event. Refer to **Standard S3.a and S3.b** for overland flow conveyance analysis requirements.
- S8.c** Owners of temporary structures shall remove and/or relocate temporary structures as required for the SFPUC to perform scheduled repair and maintenance of wastewater assets.
- S8.d** Temporary structures shall not be placed above manholes or other surface access points to wastewater assets. Temporary structures shall be a minimum of eighteen (18) inches from the edge of any manhole cover frame.
- S8.e** Sewer Laterals:
- i.** Temporary structures shall be a minimum of eighteen (18) inches from the outside edge of any sewer lateral air vent.
  - ii.** Temporary structures shall not impede the flow of sewage backups from the sewer lateral air vent to the gutter. (**Detail APS S8.2**)
  - iii.** Sewer laterals shall meet requirements outlined in the **SFPUC Sewer Lateral Standard Details and Specifications**.

### OUTCOMES

Access to critical infrastructure for routine maintenance or emergency procedures is available when temporary structures are appropriately designed and installed. Specific outcomes include the following:

- Utility access points such as valve boxes, meter boxes, vaults, sewer vents and manholes remain accessible for maintenance and operation of underground assets.
- Stormwater flow over the street and through gutters will not be unreasonably impeded by temporary structures, preventing localized flooding and allowing overland flow to continue to catch basins.
- Flow from sewage backups out of side sewer vents will not be unreasonably impeded by temporary structures, preventing localized ponding on sidewalks and limiting public exposure to raw sewage.
- Below ground utilities are protected from temporary structure loads.

# STANDARD 9: PERMANENT STRUCTURES

## OVERVIEW

Permanent structures are features that are not readily movable without the need of a special tradesman (e.g., buildings and large site furnishings including pergolas, street lights, other poles, and shade structures that are not movable). Permanent structures above water and wastewater assets may unreasonably limit the SFPUC's ability to access those assets to perform routine or emergency maintenance or repair. With this in mind, it is important that minimum setbacks are provided between permanent structures and buried SFPUC infrastructure.

## PROTECTION STANDARDS: WATER

**W9.a** Permanent structures shall not be located within the equipment staging envelope shown in *Detail APS WS9.1* and *Detail APS WS9.2*. A minimum of ten (10) horizontal feet shall be clear of permanent structures on one side of the centerline of a water asset and a minimum of fifteen (15) horizontal feet shall be clear of permanent structures on the opposite side. Within this area, a minimum of twenty (20) vertical feet above grade shall be clear of permanent structures. Exceptions are as follows:

- i. Permanent structures with a dimension of five (5) feet or smaller as measured parallel to a water asset are permitted within the equipment staging envelope, but shall not be located within five (5) horizontal feet of the outside diameter of a water asset or twenty (20) feet of an adjacent permanent structure within the staging envelope (*Detail APS WS9.1*). The outside edge of the foundation of any poles (OCS, lights) shall not be located within five (5) horizontal feet of the outside diameter of a water asset.
- ii. Water laterals shall have minimum clearance from permanent structures specified in *Standard W9.e*.



Utility excavation work for installation, maintenance, and emergency repair projects requires the use of heavy equipment. To facilitate access for this equipment, permanent structures must not be installed within the "equipment staging envelope" (*Detail APS WS9.1* and *Detail APS WS9.2*).



## STANDARD 9: PERMANENT STRUCTURES

- W9.b** Tracks and track slabs shall not be located above water assets that run parallel to the tracks. Dedicated transit right-of-ways shall provide a minimum of thirteen (13) horizontal feet between the nearest OCS wire and the outside edge of the water asset. For rail and transit projects that include site constraints where these clearances are not achievable, SFPUC staff will work with project proponents to determine clearances that will ensure SFPUC has continued safe access to SFPUC assets and that minimize disruptions to public transit operations.
- W9.c** Raised boarding platforms (with a boarding grade more than eight (8) vertical inches above the grade of the adjacent traffic lane) shall be considered permanent structures. For rail and transit projects that include site constraints where these clearances are not achievable, SFPUC staff will work with project proponents to determine clearances that will ensure SFPUC has continued safe access to SFPUC assets and that minimize disruptions to public transit operations.
- W9.d** Permanent structures, including but not limited to fences and raised boarding platforms shall not block maintenance vehicle access to valves, hydrants, manholes, and other operational appurtenances and/or access points of the water/AWSS distribution system.
- W9.e** Permanent structures shall not be located above or within two (2) horizontal feet of the outside edge of water service laterals and meter boxes / vaults.



Raised planter boxes (such as the ones pictured) are considered permanent structures, but may be allowable with adequate spacing (Standard W9.a.i and Detail APS WS9.1).

# STANDARD 9: PERMANENT STRUCTURES

## PROTECTION STANDARDS: WASTEWATER

**S9.a** Permanent structures shall not be located within the equipment staging envelope shown in *Detail APS WS9.1* and *Detail APS WS9.2*. A minimum of ten (10) horizontal feet shall be clear of permanent structures on one side of the centerline of a wastewater asset and a minimum of fifteen (15) horizontal feet shall be clear of permanent structures on the opposite side. A minimum of twenty (20) vertical feet above grade shall be clear of permanent structures. Exceptions are as follows:

- i. Permanent structures with a dimension of five (5) feet or smaller as measured parallel to a wastewater asset are permitted within the equipment staging envelope, but shall not be located within five (5) horizontal feet of the outside diameter of a wastewater asset or twenty (20) feet of an adjacent permanent structure within the staging envelope (*Detail APS WS9.1*). The outside edge of the foundation of any poles (OCS, lights) shall not be located within five (5) horizontal feet of the outside diameter of a wastewater asset.
- ii. Sewer Laterals shall have minimum clearance from permanent structures specified in *Standard S9.e*.

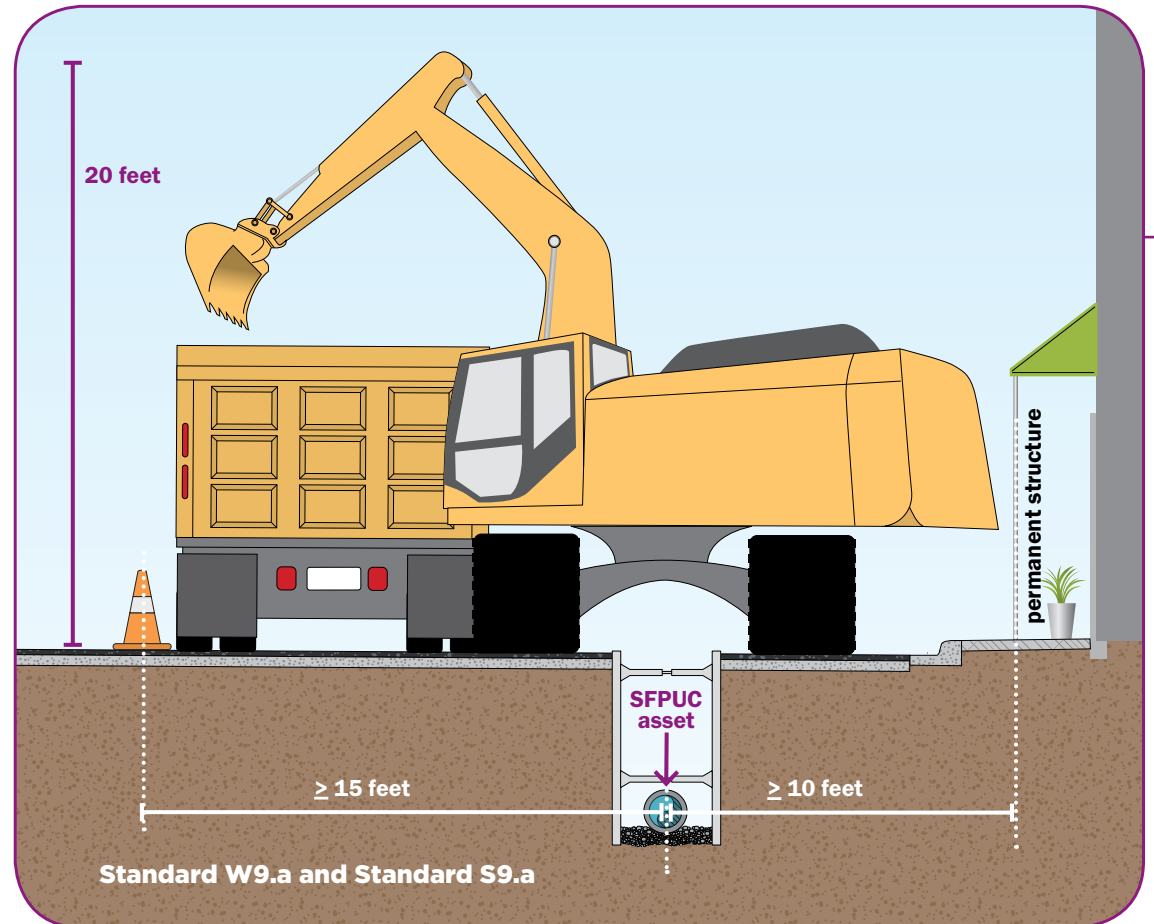

## STANDARD 9: PERMANENT STRUCTURES

- S9.b** Tracks and track slabs shall not be located above wastewater assets that run parallel to the tracks. Dedicated transit right-of-ways shall provide a minimum of thirteen (13) horizontal feet between the nearest OCS wire and the outside edge of the wastewater asset. For rail and transit projects that include site constraints where these clearances are not achievable, SFPUC staff will work with project proponents to determine clearances that will ensure SFPUC has continued safe access to SFPUC assets and that minimize disruptions to public transit operations.
- S9.c** Raised boarding platforms (with a boarding grade more than eight (8) vertical inches above the grade of the adjacent traffic lane) shall be considered permanent structures. For rail and transit projects that include site constraints where these clearances are not achievable, SFPUC staff will work with project proponents to determine clearances that will ensure SFPUC has continued safe access to SFPUC assets and that minimize disruptions to public transit operations.
- S9.d** Permanent structures, including but not limited to fences and raised boarding platforms shall not block maintenance vehicle access to manholes or other surface access points to the wastewater collection system.
- S9.e** Sewer Laterals
- i.** Permanent structures shall not be located above or within two (2) horizontal feet of the outside edge of sewer laterals or sewer lateral air vents.
  - ii.** Permanent structures shall not impede the positive flow of sewage backups from the sewer lateral air vent to the gutter. (*Detail APS S2.4*)
  - iii.** Sewer laterals shall meet requirements outlined in the *SFPUC Sewer Lateral Standard Details and Specifications*.

### OUTCOMES

Maintaining minimum clearances between buried SFPUC utilities and permanent structures allows SFPUC crews and contractors to safely operate and maintain those utilities. Specifically:

- Adequate space is provided to allow a dump truck, excavator, and trench shoring to be staged along the alignment of an underground water or sewer main.
- Utility access points such as valve boxes, meter boxes, vaults, sewer vents and manholes remain accessible for maintenance and operation of underground assets.
- Flow of sewer backups is not impacted by the presence of permanent structures, preventing localized ponding on sidewalks and limiting public exposure to raw sewage.

# STANDARD 10: UNDERGROUND UTILITY CLEARANCES

## OVERVIEW

Underground utilities installed adjacent to existing SFPUC infrastructure can make planned and emergency maintenance and upgrades to existing infrastructure difficult for SFPUC crews and contractors.

### PROTECTION STANDARDS: WATER

- W10.a** New utilities and/or underground structures shall comply with *CDD Specification 01 41 28 "Protection of Existing Water and AWSS Facilities,"* and other applicable federal, state, and local codes.
- W10.b** New utilities and/or underground structures aligned adjacent to an existing water asset shall not be installed within three (3) horizontal feet of the outside diameter of the existing water asset, as shown in *Detail APS WS10.1*.
- W10.c** New utilities and/or underground structures that cross over or under an existing water asset shall be installed as far as possible from and no closer than twelve (12) inches to the outside diameter of the water asset, as shown in *Detail APS WS10.1*.
- W10.d** New utilities and/or underground structures that cross over or under an existing water asset shall cross at an angle of forty-five (45) to ninety (90) degrees, as measured between the centerline of the crossing utility and the water asset. (*Detail APS WS10.1*)



Maintaining minimum clear spaces around existing underground SFPUC assets ensures that SFPUC crews and contractors are able to excavate around those assets and install shoring for required maintenance work.



# STANDARD 10: UNDERGROUND UTILITY CLEARANCES

## PROTECTION STANDARDS: WASTEWATER

- S10.a** New utilities and/or underground structures shall comply with all applicable federal, state, and local codes.
- S10.b** New utilities and/or underground structures aligned adjacent to an existing wastewater asset shall not be installed within three and a half (3.5) horizontal feet of the outside diameter of the existing wastewater asset, as shown in *Detail APS WS10.1*.
- S10.c** New utilities and/or underground structures that cross over or under an existing wastewater asset shall be installed as far as possible from and no closer than twelve (12) inches to the outside diameter of the wastewater asset, as shown in *Detail APS WS10.1*.
- S10.d** New utilities and/or underground structures that cross over or under an existing wastewater asset shall cross at an angle of forty-five (45) to ninety (90) degrees, as measured between the centerline of the crossing utility and the wastewater asset. See *Detail APS WS10.1*.

## OUTCOMES

Maintaining minimum clearance from existing SFPUC infrastructure ensures that SFPUC crews and contractors will have the ability to safely and expeditiously maintain and improve such infrastructure in the future. Specifically:

- Crews and contractors will have adequate space to tap mains for new service connections.
- Crews and contractors will have adequate space to properly shore trenches, providing a safe working environment for main maintenance and replacement projects.
- Heavy equipment operators will be able to better avoid damaging crossing utilities during excavation, therefore avoiding disruptions in utility service to the general public.
- Projects will avoid waiting periods for conflicting utility relocation during maintenance and replacement projects, therefore reducing project construction schedules.

# PROJECT REVIEW

The City Distribution and Collection Systems Divisions of the SFPUC encourage project sponsors to submit project plans as early as feasible during the design process for review. Review staff from CDD and CSD will examine submittals for compliance with the Asset Protection Standards (along with other applicable regulatory requirements) and work with project sponsors to resolve potential conflicts with existing SFPUC infrastructure. Working with review staff early in the project planning & design process allows project designers to modify designs to avoid utility relocation work where possible, and allows for project managers to appropriately budget for SFPUC utility work when it cannot be avoided.

Project proponents shall submit documentation per the process prescribed for type of project being implemented. Typical examples of workflows for project review are listed below. Project proponents should ensure that they provide all the required submittals for the specific project type to ensure a thorough and timely review of documentation.

## EXAMPLE PROJECT WORKFLOWS

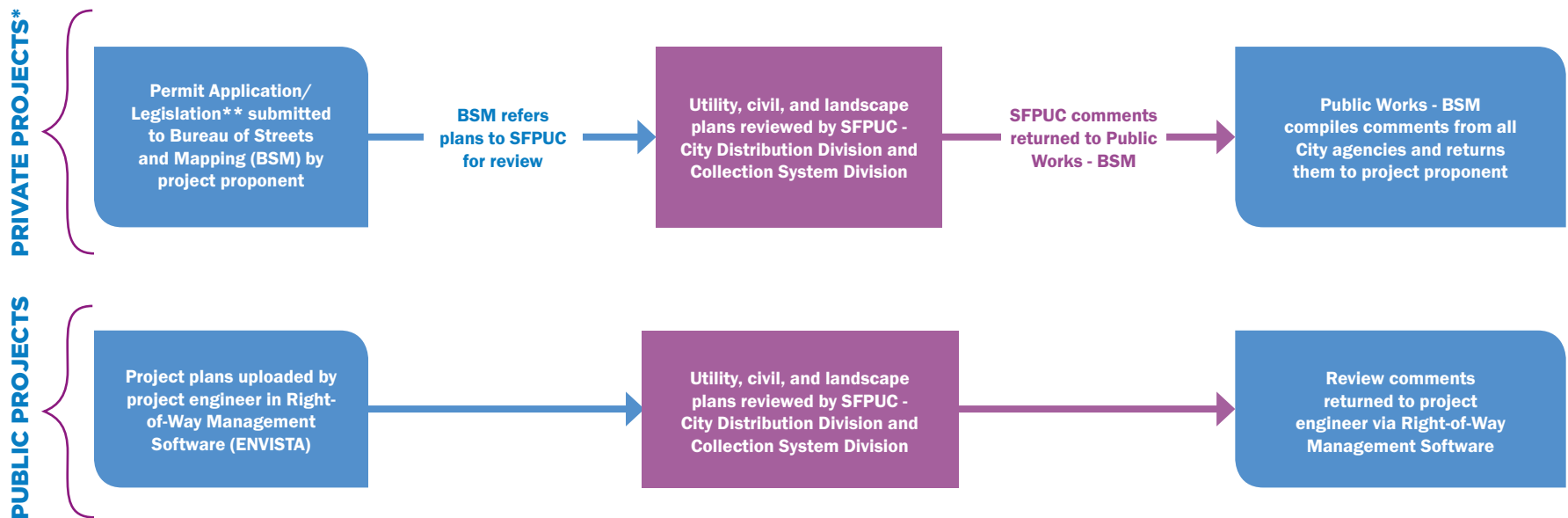

\* This flowchart is typical of private development projects. Some private projects may follow a submittal review process prescribed in that project's specific development MOU.

\*\* Typical examples are proposed sidewalk change legislation, proposed street vacation legislation, street improvement permit application, major encroachment permit application, etc. See <http://sfdpw.org/index.aspx?page=1597>.

# VARIANCE PROCESS

Subsurface utility congestion, safety considerations, legal/real estate requirements and other additional factors may sometimes make it difficult for projects to be in compliance with all Standards listed herein. If a project sponsor cannot comply with certain Standards due to physical site constraints or factors listed above, SFPUC will consider issuing variances to the Standards.

A flow chart for variance review is provided in the figure below. Requests for variance will be processed by the Collection Systems Division or City Distribution Division project reviewer and escalated to the appropriate division manager. Along with any supporting documentation or drawings, project proponents should submit cover letters for variance requests explaining (1) why the variance is necessary and (2) how the proposed design / design mitigation meets the intentions and outcomes of the original Standard.

The Asset Protection Standards only apply to existing right-of-ways and infrastructure. Accordingly, variances to the Asset Protection Standards will not be considered for projects installing new water or wastewater infrastructure or developing completely new streets. In these situations, projects are asked instead to request variances to the standards or regulations applicable to that specific project (i.e. Subdivision Regulations) through the appropriate process applicable to that project (i.e. Infrastructure Task Force).

## VARIANCE REVIEW PROCESS

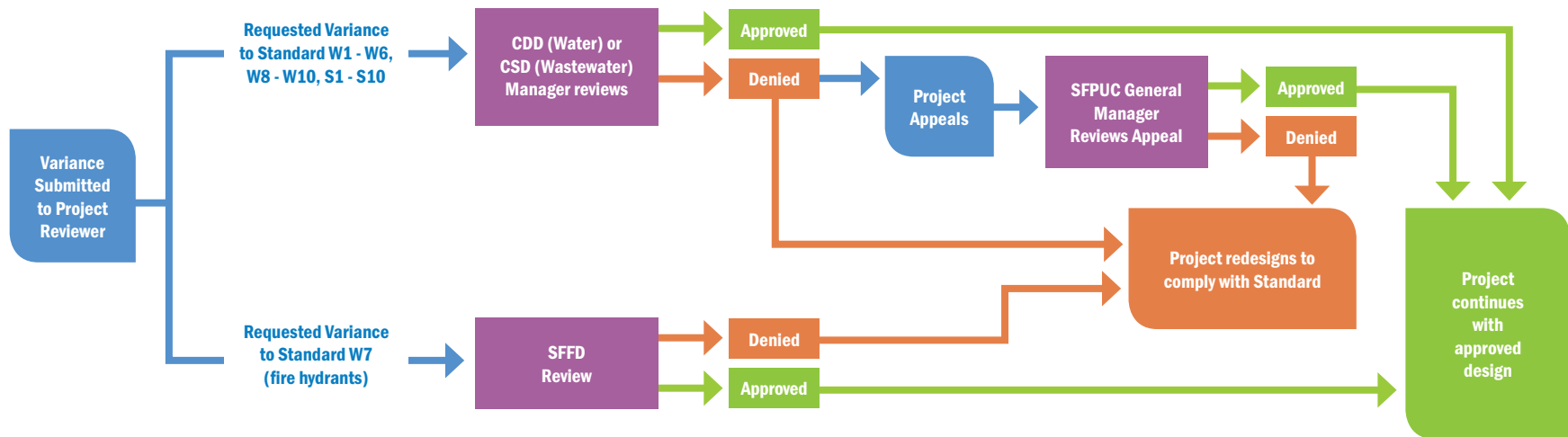

This page intentionally left blank.



# APPENDIX A: DEFINITIONS AND REFERENCES

## SFPUC Asset Protection Standards

This page intentionally left blank.

## APPENDIX A: DEFINITIONS

**Americans with Disabilities Act (ADA):** Law that prohibits discrimination against individuals with disabilities.

**Asset:** Any facility owned, maintained and operated by the San Francisco Public Utilities Commission, including service laterals between the main and the customer point of connection.

**AWSS Asset:** Asset that is a component of the Auxiliary Water Supply System (also referred to as the High Pressure Water System [HPWS]).

**CDD:** City Distribution Division (San Francisco potable, recycled, and auxiliary water supply system division of the SFPUC, also referred to as the San Francisco Water Department [SFWD])

**Cover:** Distance between the finished grade of the right-of-way and the top of a SFPUC Asset.

**Cover (Valve, Meter, or Manhole):** Precast concrete or iron lid protecting and/or providing access to an SFPUC asset.

**CSD:** Collection System Division (San Francisco wastewater collection system operator of the SFPUC)

**Public Works:** San Francisco Public Works (formerly San Francisco Department of Public Works)

**Drainage Management Area (DMA):** An individual discrete area or subwatershed that typically follows grade breaks and roof ridge lines. A DMA drains to its own green stormwater infrastructure facility.

**Edge Treatments:** Edge treatments are rigid perimeters (typically formed of concrete) that prevent pavement from shifting horizontally and helps to minimize differential settlement between traditional pavement and permeable pavement (also referred to as flush vertical curbs).

**H-20:** Traffic Load Design Rating defined by the American Association of Highway Transportation Officials (AASHTO).

**Lateral:** Water or sewer pipe extending from a main to a property served by the San Francisco Public Utilities Commission.

**Lower Sewer Lateral:** The portion of the sewer lateral from the curb to the sewer main.

**Main:** A principal water or sewer conveyance pipe in the distribution/collection systems, typically aligned parallel to the center of the street.

**Manhole:** A covered, at-grade access point to subsurface utility infrastructure.

**Meter Box / Vault:** An at-grade water utility box or vault containing a water meter.

**MTA:** San Francisco Municipal Transportation Agency

**Operable Asset:** Asset that must be accessible by SFPUC staff to control and monitor the operation of the potable/recycled/auxiliary water distribution system or wastewater collection system.

**Overhead Contact System (OCS):** Overhead electric infrastructure operated by the San Francisco Municipal Transportation Agency that powers transit vehicles.

**Permanent Structure:** Any structure or furnishing that is not readily moveable without the need of a special tradesman (e.g. raised boarding platforms, buildings and large site furnishings including but not limited to pergolas, street lights, other poles, shade structures, etc).

**Potable Water Asset:** Any asset that is a component of the Potable Water Supply System (also referred to as [PWSS], Domestic Water Supply System [DWSS], and Low Pressure Water System [LPWS]).

**Raised Boarding Platform:** Boarding platform for transit operations that has a boarding grade greater than eight (8) vertical inches above the grade of the adjacent transit/traffic lane.

## APPENDIX A: DEFINITIONS

**Recycled Water Asset:** Any asset that is a component of the Recycled Water Supply System (also referred to as RWSS).

**Sidewalk Extension:** A widening of an existing sidewalk (may be referred to as a bulb-out, bus-bulb-out, sidewalk widening, etc.).

**Temporary Structure:** Any structure or furnishing that is not classified as a permanent structure.

**Upper Sewer Lateral:** The portion of the lateral from the property to the curb.

## APPENDIX A: REFERENCES

**Better Streets Plan and Complete Streets Policy:** San Francisco's policies encourage the design and development of 'Better Streets' – streets that work for all users. A Better Street attends to the needs of people first, considering pedestrians, bicyclists, transit, street trees, stormwater management, utilities, and livability as well as vehicular circulation and parking.

Published by San Francisco Planning Department  
[www.sfbetterstreets.org](http://www.sfbetterstreets.org)

**Public Works Accessible Street Crossing Standards:** San Francisco Standard Specifications & Plans for the installation of curb ramps at street crossings.

Published by San Francisco Public Works  
[sfpublicworks.org/services/standards-specifications-and-plans](http://sfpublicworks.org/services/standards-specifications-and-plans)

**Public Works Standard Specifications and Plans:** General Standard Plans & Specifications for the construction of public streets.

Published by San Francisco Public Works  
[sfpublicworks.org/services/standards-specifications-and-plans](http://sfpublicworks.org/services/standards-specifications-and-plans)

**SFPUC City Distribution Division Standard Specifications and Plans:** SFPUC Water Enterprise – City Distribution Division Plans and Specifications for the installation of new potable, recycled and AWSS water infrastructure.

Published by the San Francisco Public Utilities Commission  
[sfwater.org/reqs](http://sfwater.org/reqs)

**SFPUC Sewer Lateral Standard Plans and Specifications:** SFPUC Wastewater Enterprise – Collection Systems Division Plans and Specifications for new wastewater service lateral installation.

To be published Fall 2017 by the San Francisco Public Utilities Commission  
[sfwater.org/reqs](http://sfwater.org/reqs)

**SFPUC Green Infrastructure Typical Details, Phase II:** Typical Details for the design & construction of green infrastructure elements within the public right-of-way.

Published by the San Francisco Public Utilities Commission  
[sfwater.org/sdg](http://sfwater.org/sdg)

# **APPENDIX B: STANDARD DETAIL DRAWINGS**

## **SFPUC Asset Protection Standards**

APS WS 2.1 Minimum Clearance between New Curb & Gutter and Existing SFPUC Covers

APS W 2.2 Sidewalk Encroachment on Existing Potable/Recycled Water Assets

APS W 2.3 Sidewalk Encroachment on Existing Aux Water Supply System Assets

APS S 2.4 Sewer Lateral Air Vent & Trap Relocation at Sidewalk Extensions & Bulb Outs

APS WS 3.1 Minimum Cover Over Existing SFPUC Assets

APS W 7.1 Requirements for Existing Low Pressure Fire Hydrants at New Bulb Outs

APS W 7.2 Requirements for Existing AWSS Fire Hydrants at New Bulb Outs

APS W 8.1 Minimum Clearance from Temporary Structures to Existing Water Assets

APS S 8.2 Minimum Clearance from Temporary Structures to Existing Wastewater Assets

APS WS 9.1 Minimum Clearance from Permanent Structures to Existing SFPUC Assets (Plan)

APS WS 9.2 Minimum Clearance from Permanent Structures to Existing SFPUC Assets (Profile)

APS WS 10.1 Minimum Clearance from Underground Utilities to Existing SFPUC Assets

This page intentionally left blank.

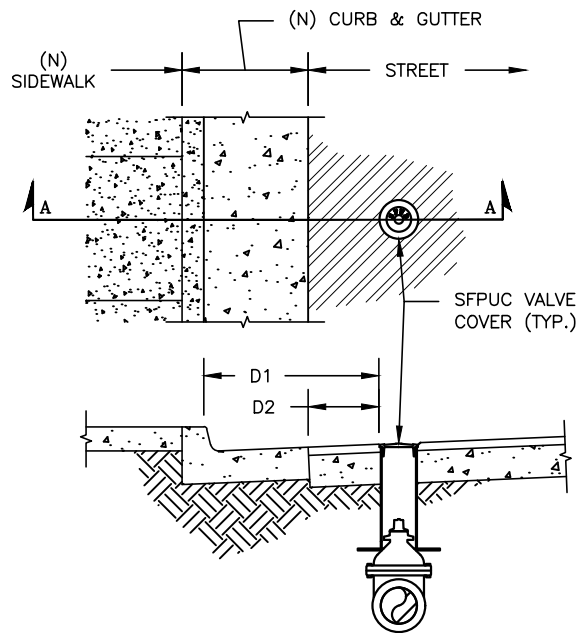

**A CLEARANCE FROM SFPUC VALVE COVER**

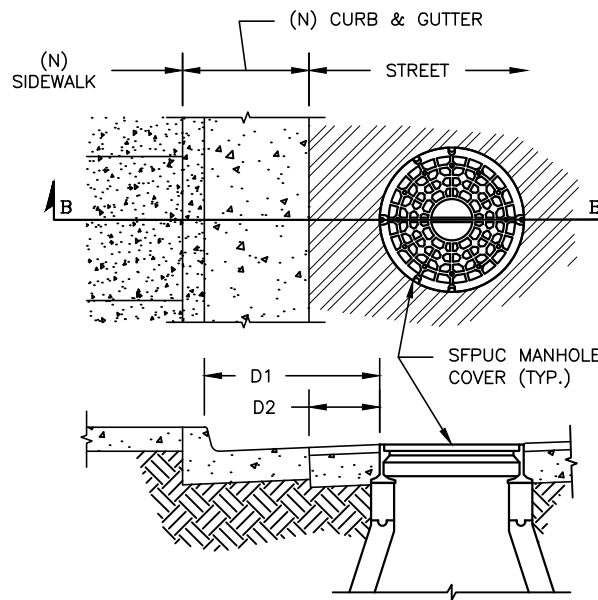

**B CLEARANCE FROM SFPUC MANHOLE COVER**

REFER TO SFPUC STANDARD APS W2.B AND APS S2.A FOR FULL TEXT OF REQUIREMENTS

**MINIMUM CLEARANCES FROM NEW CURB AND GUTTER\***

- D1 18 INCHES CURB FACE TO EDGE OF VALVE BOX / MANHOLE COVER FRAME\*\*
- D2 6 INCHES LIP OF GUTTER TO EDGE OF VALVE BOX / MANHOLE COVER FRAME\*\*

\* MINIMUM DIMENSIONS ONLY APPLY TO LOCATIONS WHERE SIDEWALK IS BEING EXTENDED / CURB ALIGNMENT IS BEING ADJUSTED. FOR STANDARD INSTALLATION LOCATION OF NEW WATER AND WASTEWATER INFRASTRUCTURE, REFER TO APPROPRIATE INSTALLATION SPECIFICATIONS OR SUBDIVISION REGULATIONS.

\*\* FOR STANDARD APS W2.B AND APS S2.A, MEASUREMENTS D1 AND D2 ARE TAKEN AT STREET GRADE TO THE EDGE OF THE VALVE BOX / MANHOLE COVER FRAME WHEN A FRAME IS PRESENT. WHEN NO FRAME PRESENT, THE MEASUREMENT IS TAKEN TO THE EDGE OF THE COVER.



DATE 05/01/2017

SCALE N.T.S

REV.

0

SFPUC STANDARDS FOR THE PROTECTION OF WATER AND WASTEWATER ASSETS

MINIMUM CLEARANCE BETWEEN NEW CURB & GUTTER AND EXISTING SFPUC COVERS

DWG # APS WS2.1

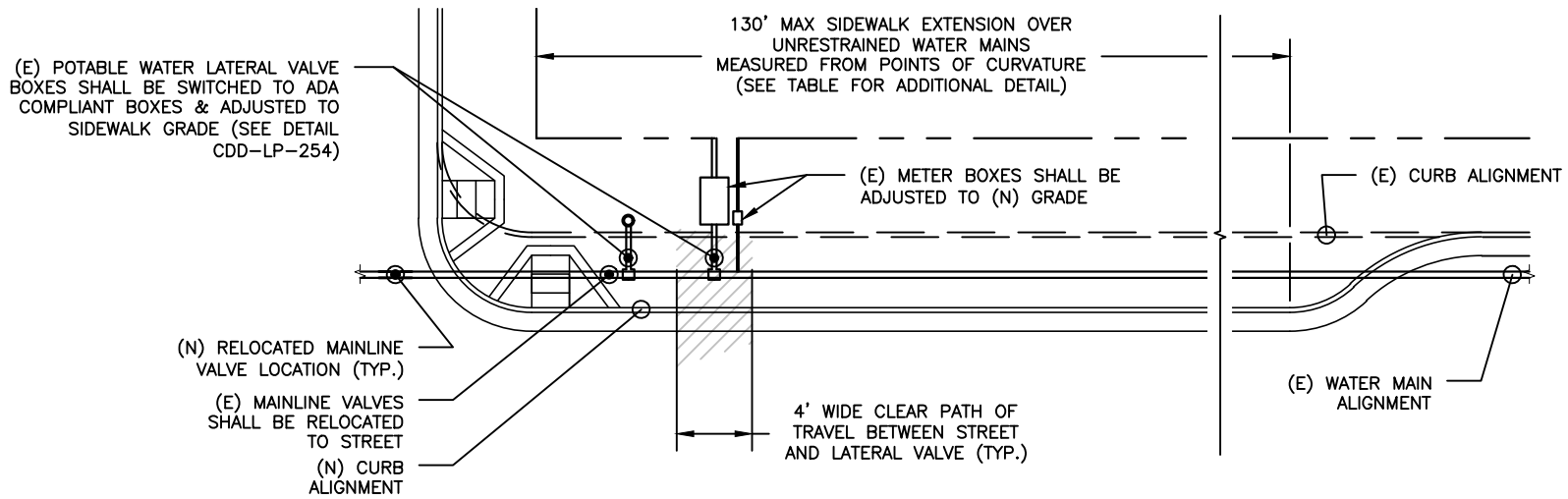

DESCRIPTION OF SFPUC WATER ASSET IN SIDEWALK	REQUIRED ACTION BASED ON LENGTH OF SIDEWALK EXTENSION / BULB OUT	
	<= 130 FEET	> 130 FEET
POTABLE/RECYCLED WATER CAST IRON MAIN (UNRESTRAINED)	A.	B.
POTABLE/RECYCLED WATER DUCTILE IRON MAIN INSTALLED BEFORE JAN 1, 1985 (UNRESTRAINED)	A.	B.
POTABLE/RECYCLED WATER DUCTILE IRON MAIN INSTALLED ON OR AFTER JAN 1, 1985 (RESTRAINED)	A.	D.
POTABLE/RECYCLED WATER MAIN – OTHER PIPE MATERIAL	A.	D.
POTABLE/RECYCLED WATER MAIN ISOLATION VALVE	B.	B.
POTABLE/RECYCLED WATER LATERAL ISOLATION VALVE	C.	C.
POTABLE/RECYCLED WATER FIRE HYDRANT	REFER TO STANDARD APS W7	

**KEY:**

- A. PROJECT REQUIRED TO NOTIFY SFPUC OF PLANNED WORK VIA NOTICE OF INTENT PROCESS. SFPUC-CDD MAY ELECT TO REPLACE ASSETS PRIOR TO CONSTRUCTION OF SIDEWALK EXTENSION.
- B. PROJECT REQUIRED TO RELOCATE OR RENEW PIPE/VALVE IN COORDINATION WITH SFPUC-CDD.
- C. PROJECT REQUIRED TO REPLACE CAST IRON VALVE COVERS WITH ADA-COMPLIANT COVERS PER STANDARD DETAIL CDD-LP-254.
- D. SFPUC-CDD WILL REVIEW CONDITION OF EXISTING WATER ASSET IN CONJUNCTION WITH DESIGN PLANS TO DETERMINE IF THE PIPE NEEDS TO BE RELOCATED (ON A CASE-BY-CASE BASIS).

**NOTES:**

- 1. SIDEWALK EXTENSION IS CONSIDERED TO BE OVER A WATER MAIN IF THE FACE OF THE CURB OR LIP OF THE GUTTER CROSSES OVER THE OUTSIDE DIAMETER OF THE MAIN.
- 2. REFER TO STANDARD APS W2.C FOR FULL TEXT OF REQUIREMENTS.



**San Francisco Water Power Sewer**  
Services of the San Francisco Public Utilities Commission

DATE 05/01/2017

REV.

0

SCALE N.T.S

SFPUC STANDARDS FOR THE PROTECTION OF WATER AND WASTEWATER ASSETS

**SIDEWALK ENCROACHMENT ON EXISTING POTABLE/RECYCLED WATER ASSETS**

DWG # **APS W2.2**



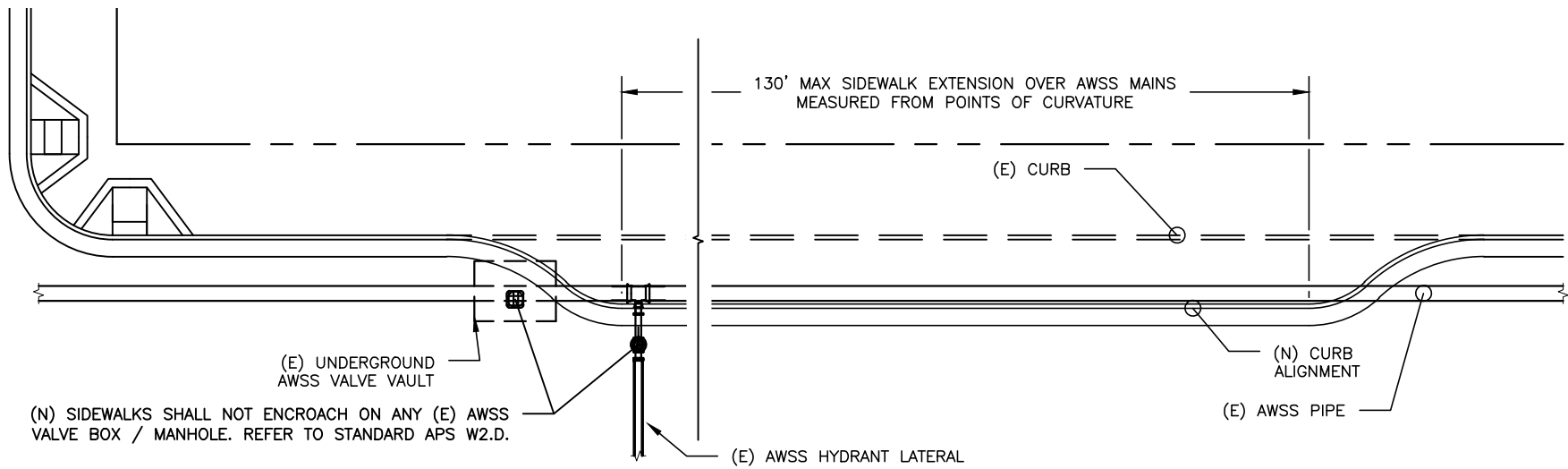

SFPUC WATER ASSET IN SIDEWALK	ACTION BASED ON LENGTH OF SIDEWALK EXTENSION	
	<= 130 FEET	> 130 FEET
AWSS MAIN – ANY PIPE MATERIAL	A.	B.
AWSS MAIN ISOLATION VALVE	B.	B.
AWSS LATERAL ISOLATION VALVE	B.	B.
AWSS FIRE HYDRANT	REFER TO STANDARD APS W7	

**KEY:**

- A. PROJECT REQUIRED TO NOTIFY SFPUC OF PLANNED WORK VIA NOTICE OF INTENT PROCESS. SFPUC–CDD MAY ELECT TO REPLACE ASSETS PRIOR TO CONSTRUCTION OF SIDEWALK EXTENSION.
- B. PROJECT REQUIRED TO RELOCATE OR RENEW PIPE/VALVE IN COORDINATION WITH SFPUC–CDD.

**NOTES:**

- 1. SIDEWALK EXTENSION IS CONSIDERED TO BE OVER AN AWSS MAIN IF THE FACE OF THE CURB OR LIP OF THE GUTTER CROSSES OVER THE OUTSIDE DIAMETER OF THE MAIN.
- 2. REFER TO STANDARD APS W2.D FOR FULL TEXT OF REQUIREMENTS.



**San Francisco  
Water Power Sewer**  
Services of the San Francisco Public Utilities Commission

DATE 05/01/2017

SCALE N.T.S

REV.

0

SFPUC STANDARDS FOR THE PROTECTION OF WATER AND WASTEWATER ASSETS

**SIDEWALK  
ENCROACHMENT ON  
EXISTING AUX WATER  
SUPPLY SYSTEM ASSETS**

DWG #  
**APS W2.3**

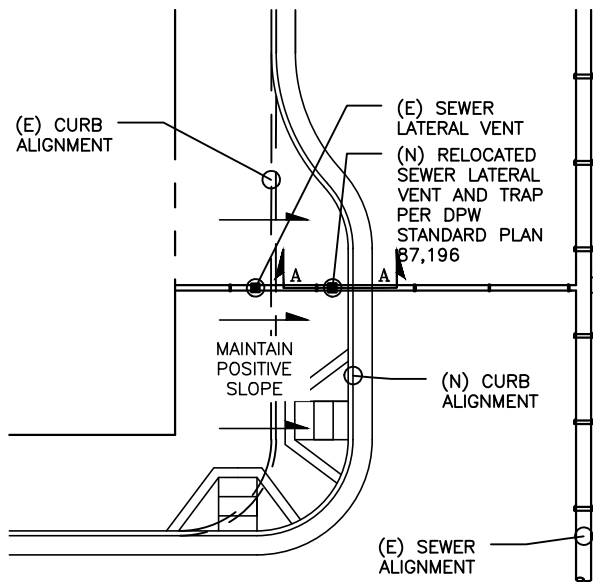

- PLAN VIEW  
- N.T.S.

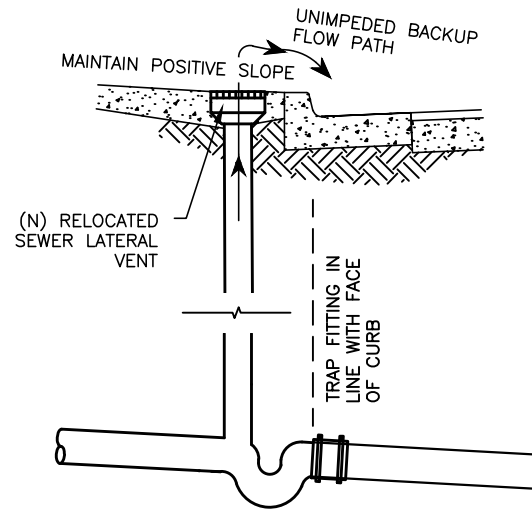

A SEWER LATERAL VENT PROFILE VIEW  
- N.T.S.

**NOTE:**

REFER TO SFPUC STANDARD APS S2.D FOR FULL TEXT OF REQUIREMENTS



**San Francisco  
Water Power Sewer**  
Services of the San Francisco Public Utilities Commission

DATE 05/01/2017

SCALE N.T.S.

REV.

0

SFPUC STANDARDS FOR THE PROTECTION OF WATER AND WASTEWATER ASSETS

SEWER LATERAL AIR VENT & TRAP RELOCATION AT SIDEWALK EXTENSIONS & BULB OUTS

DWG # APS S2.4

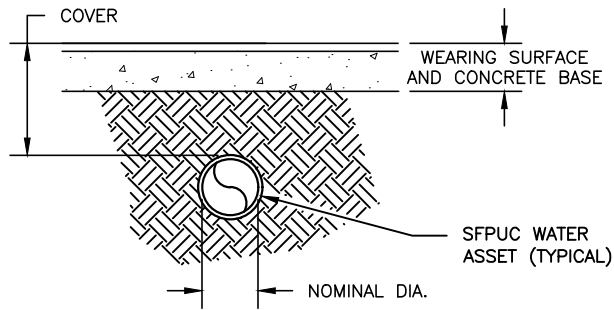

MINIMUM COVER FOR DUCTILE IRON, CAST IRON, PLASTIC AND COPPER PIPE

NOMINAL DIAMETER	MINIMUM COVER
0 TO 2 INCHES	22 INCHES
4 TO 10 INCHES	28 INCHES
12 INCHES	32 INCHES
14 TO 16 INCHES	38 INCHES
18 TO 20 INCHES	34 INCHES
> 20 INCHES	31 INCHES

MINIMUM COVER FOR ALL STEEL PIPE SHALL BE 48-INCHES (4 FEET)

MAXIMUM COVER REQUIREMENTS FOR ALL MATERIAL:

IF A PROJECT RESULTS IN A GRADE CHANGE OF MORE THAN 12 INCHES AND CAUSES THE INVERT OF A WATER PIPE TO BE MORE THAN 60 INCHES BELOW FINAL FINISHED GRADE, THE PROJECT SHALL BE RESPONSIBLE FOR REPLACING THE AFFECTED PIPELINE AT STANDARD DEPTH. SEE PLAN CDD-LP-002.

A WATER PIPE MINIMUM COVER  
- N.T.S.

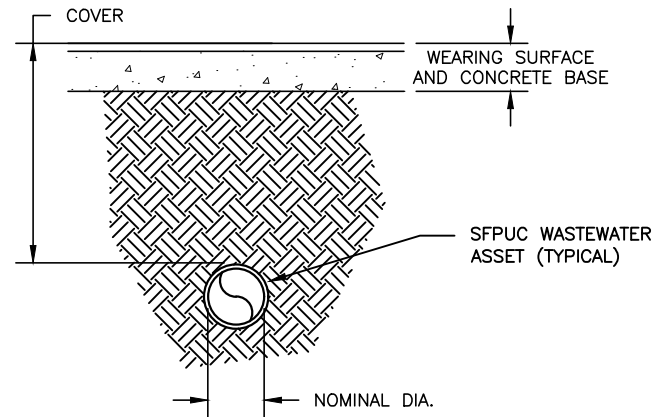

MINIMUM COVER FOR WASTEWATER PIPE (ALL MATERIALS)

NOMINAL DIAMETER	MINIMUM COVER
ANY	72 INCHES

B WASTEWATER PIPE MINIMUM COVER  
- N.T.S.

NOTE:

REFER TO SFPUC STANDARD APS W3.A AND S3.A FOR FULL TEXT OF REQUIREMENTS



**San Francisco  
Water Power Sewer**  
Services of the San Francisco Public Utilities Commission

DATE 05/01/2017

SCALE N.T.S.

REV.

0

SFPUC STANDARDS FOR THE PROTECTION OF WATER AND WASTEWATER ASSETS

MINIMUM COVER OVER EXISTING SFPUC ASSETS

DWG #  
APS WS3.1

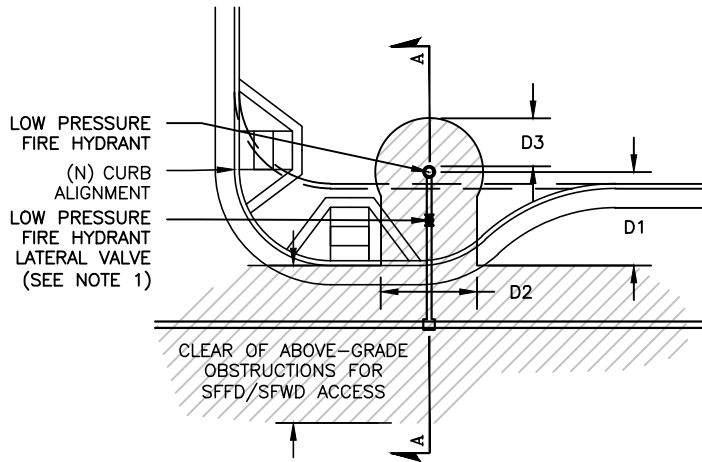

- LPFH PLAN VIEW AT BULB OUT  
- N.T.S.

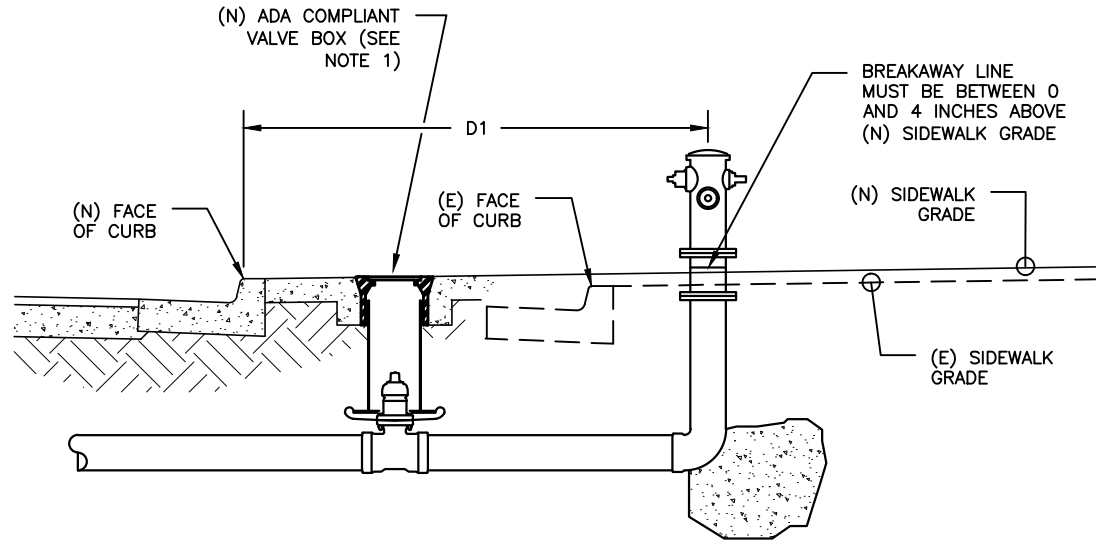

A LOW PRESSURE HYDRANT LATERAL PROFILE AT BULB OUT  
- N.T.S.

**NOTES:**

1. LOW PRESSURE HYDRANT LATERAL VALVES PERMITTED IN SIDEWALK ONLY AS PRESCRIBED IN STANDARD APS W2.C. REFER TO STANDARD DETAIL CDD-LP-254 FOR ADJUSTMENT TO STREET OR SIDEWALK GRADE.
2. WIDTH FROM THE CENTER OF THE HYDRANT TO THE FIRST ROADWAY TRAVEL LANE IS DEFINED AS THE WIDTH OF THE WIDENED SIDEWALK PLUS THE WIDTH OF ANY PARKING LANE OR OTHER OBSTRUCTION TO A FIRE ENGINE (IF PRESENT).

DIM	DESCRIPTION	MINIMUM DIMENSION*	MAXIMUM DIMENSION*
D1	DISTANCE FROM CENTER OF HYDRANT TO FIRST ROADWAY TRAVEL LANE (SEE NOTE 2)	24 INCHES	9 FEET
D2	WIDTH OF CLEAR PATH BETWEEN FIRE ENGINE AND HYDRANT	10 FEET	N/A
D3	ABOVE GRADE CLEARANCE AROUND OUTSIDE CIRCUMFERENCE OF HYDRANT BARREL	5 FEET	N/A

**\*ATTENTION:**

DIMENSIONS SHOWN HEREIN ONLY APPLY TO EXISTING HYDRANTS THAT FALL WITHIN THE FOOTPRINT OF NEW PEDESTRIAN AND BUS BULB OUTS BEING ADDED TO EXISTING SIDEWALKS.

REFER TO DRAWING CDD-LP-004 FOR NEW LOW PRESSURE HYDRANT INSTALLATION AND AWSS STANDARD DRAWING 4 FOR NEW AWSS HYDRANT INSTALLATION REQUIREMENTS.

IN LOCATIONS WHERE AN ENTIRE BLOCK FACE IS BEING WIDENED, ALL HYDRANTS SHALL BE RELOCATED PER DRAWING CDD-LP-004 AND AWSS STANDARD DRAWING 4.

VARIANCES TO DIMENSIONS SPECIFIED HEREIN MUST BE APPROVED IN WRITING BY THE ASSISTANT DEPUTY CHIEF OF THE SAN FRANCISCO FIRE DEPARTMENT'S DIVISION OF SUPPORT SERVICES.



DATE 05/01/2017		REV. 1	SFPUC STANDARDS FOR THE PROTECTION OF WATER AND WASTEWATER ASSETS	REQUIREMENTS FOR EXISTING LOW PRESSURE FIRE HYDRANTS AT NEW BULB OUTS	DWG # APS W7.1
SCALE N.T.S.					

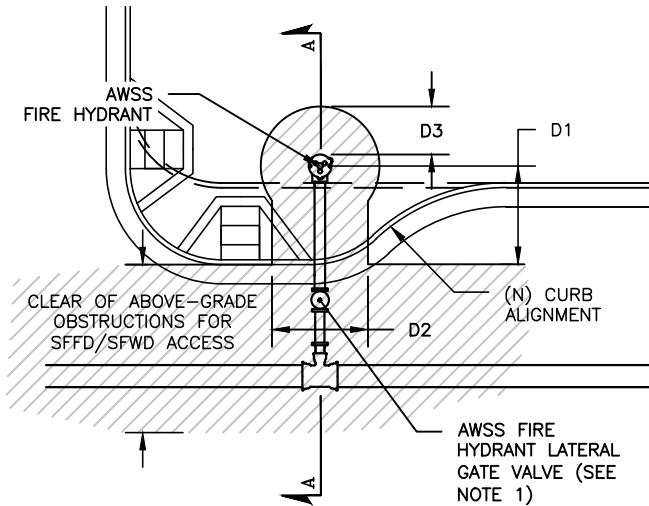

— AWSS HYDRANT PLAN VIEW AT BULB OUT  
 — N.T.S.

**NOTES:**

1. AWSS HYDRANT LATERAL VALVES ARE NOT PERMITTED IN THE SIDEWALK.
2. WIDTH FROM THE CENTER OF THE HYDRANT TO THE FIRST ROADWAY TRAVEL LANE IS DEFINED AS THE WIDTH OF THE WIDENED SIDEWALK PLUS THE WIDTH OF ANY PARKING LANE OR OTHER OBSTRUCTION TO A FIRE ENGINE (IF PRESENT).

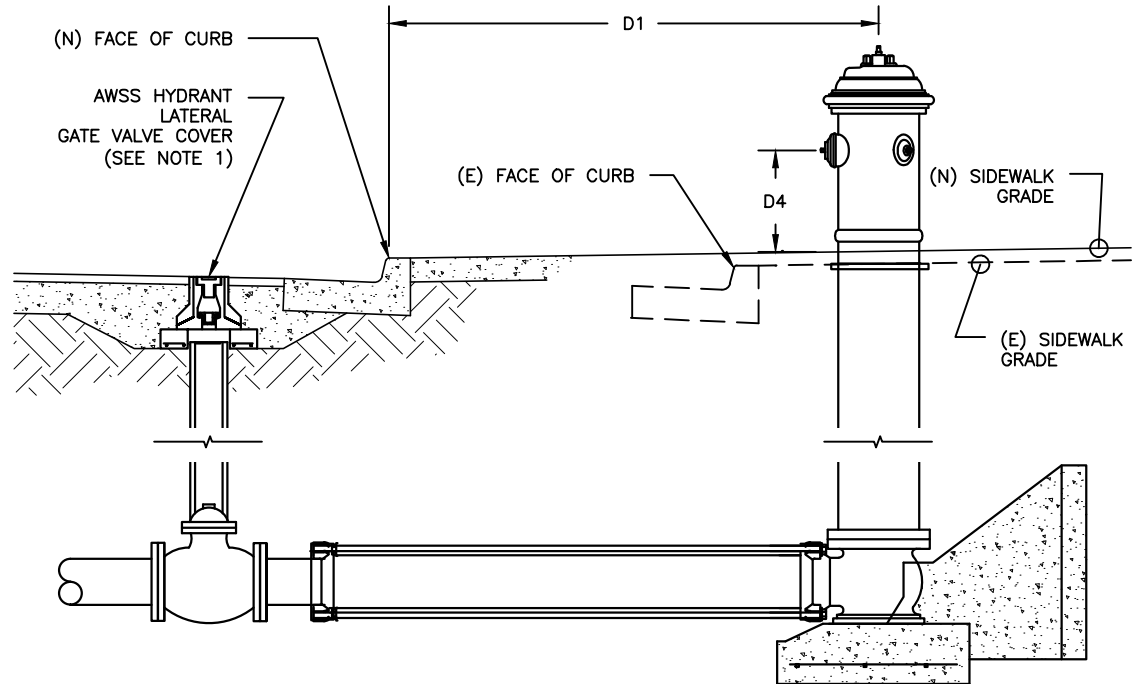

A AWSS HYDRANT LATERAL PROFILE AT BULB OUT  
 — N.T.S.

**\*ATTENTION:**

DIMENSIONS SHOWN HEREIN ONLY APPLY TO EXISTING HYDRANTS THAT FALL WITHIN THE FOOTPRINT OF NEW PEDESTRIAN AND BUS BULB OUTS BEING ADDED TO EXISTING SIDEWALKS.

REFER TO DRAWING CDD-LP-004 FOR NEW LOW PRESSURE HYDRANT INSTALLATION AND AWSS STANDARD DRAWING 4 FOR NEW AWSS HYDRANT INSTALLATION REQUIREMENTS.

IN LOCATIONS WHERE AN ENTIRE BLOCK FACE IS BEING WIDENED, ALL HYDRANTS SHALL BE RELOCATED PER DRAWING CDD-LP-004 AND AWSS STANDARD DRAWING 4.

VARIANCES TO DIMENSIONS SPECIFIED HEREIN MUST BE APPROVED IN WRITING BY THE ASSISTANT DEPUTY CHIEF OF THE SAN FRANCISCO FIRE DEPARTMENT'S DIVISION OF SUPPORT SERVICES.

DIM	DESCRIPTION	MINIMUM DIMENSION*	MAXIMUM DIMENSION*
D1	DISTANCE FROM CENTER OF HYDRANT TO FIRST ROADWAY TRAVEL LANE (SEE NOTE 2)	24 INCHES	9 FEET
D2	WIDTH OF CLEAR PATH BETWEEN FIRE ENGINE AND HYDRANT	10 FEET	N/A
D3	ABOVE GRADE CLEARANCE AROUND OUTSIDE CIRCUMFERENCE OF HYDRANT BARREL	5 FEET	N/A
D4	OFFSET FROM CENTER OF OUTLET FACING CURB TO FINISHED SIDEWALK GRADE	19 1/4 INCHES	20 3/4 INCHES



DATE 05/01/2017

SCALE N.T.S.

REV.

1

SFPUC STANDARDS FOR THE PROTECTION OF WATER AND WASTEWATER ASSETS

REQUIREMENTS FOR EXISTING AWSS HYDRANTS AT NEW BULB OUTS

DWG # APS W7.2

**NOTE:**

REFER TO SFPUC STANDARD APS W8.B FOR FULL TEXT OF REQUIREMENTS

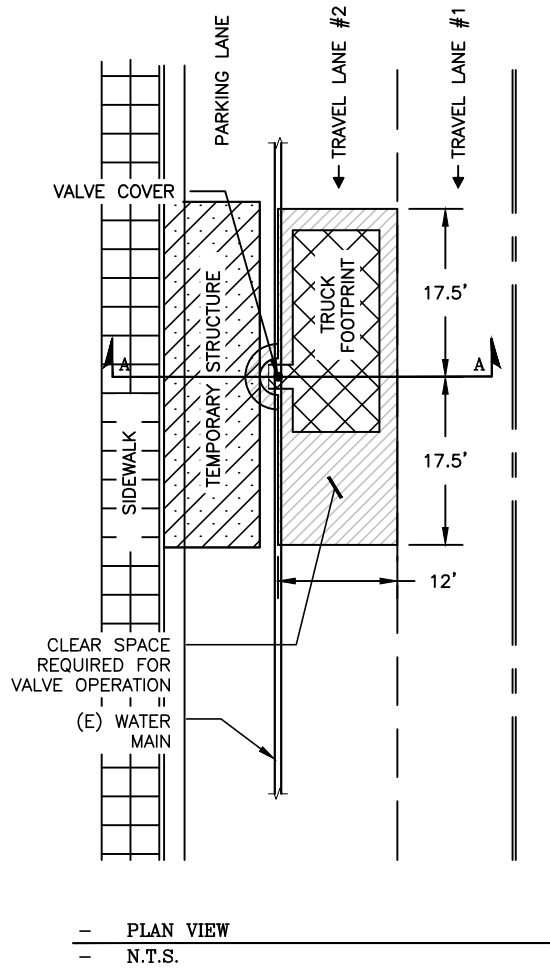

DIM	DESCRIPTION	CLEARANCE
D1	RADIAL CLEARANCE FROM EDGE OF VALVE COVER TO TEMPORARY STRUCTURE AT STREET GRADE	18 INCHES
D2	RADIAL CLEARANCE FROM EDGE OF VALVE COVER TO TEMPORARY STRUCTURE AT A PLANE 36 INCHES ABOVE STREET GRADE	36 INCHES
D3	MINIMUM VERTICAL CLEARANCE FOR HAND WHEEL OPERATION	36 INCHES

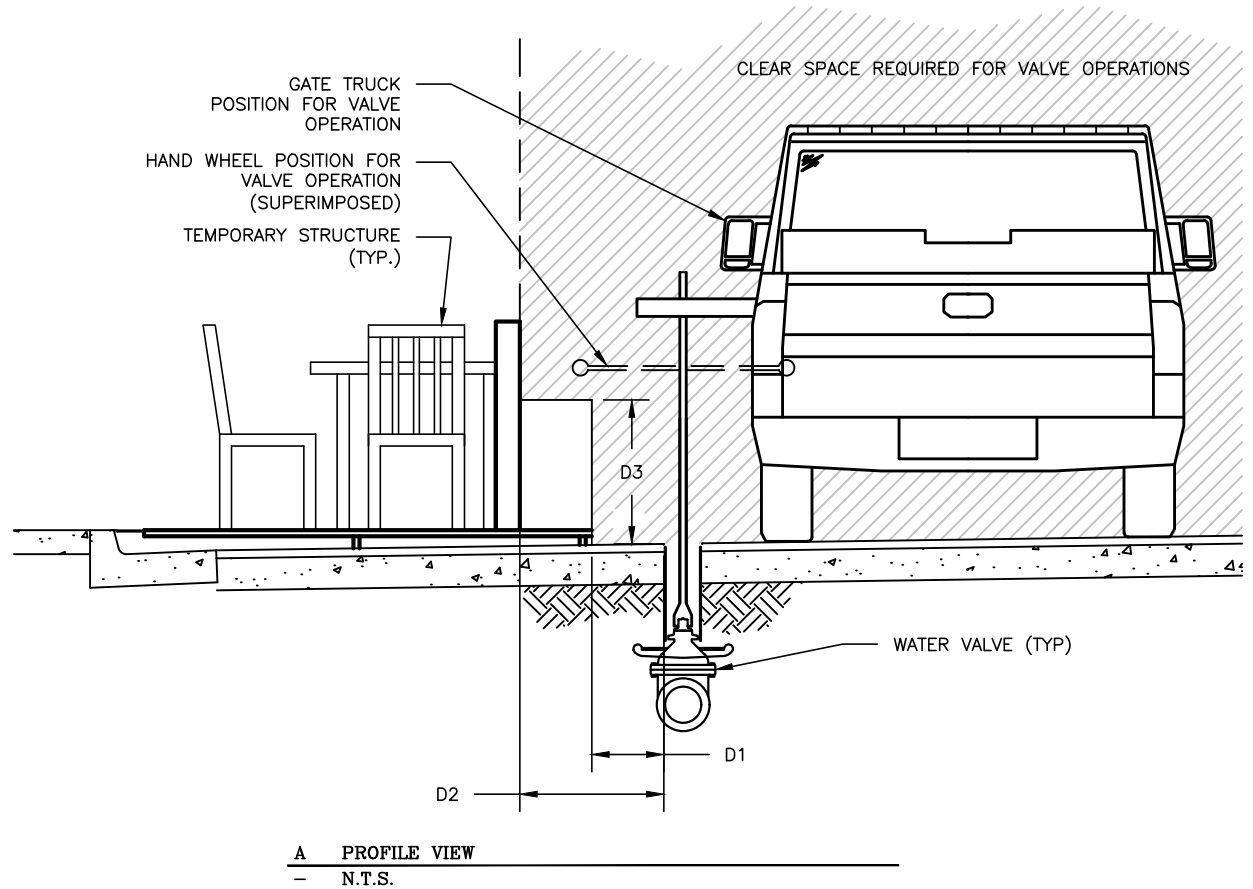

**San Francisco  
Water Power Sewer**  
Services of the San Francisco Public Utilities Commission

DATE 05/01/2017

REV.

0

SCALE N.T.S.

SFPUC STANDARDS FOR THE PROTECTION OF WATER AND WASTEWATER ASSETS

**MINIMUM CLEARANCE FROM TEMPORARY STRUCTURES TO EXISTING WATER ASSETS**

DWG # APS W8.1

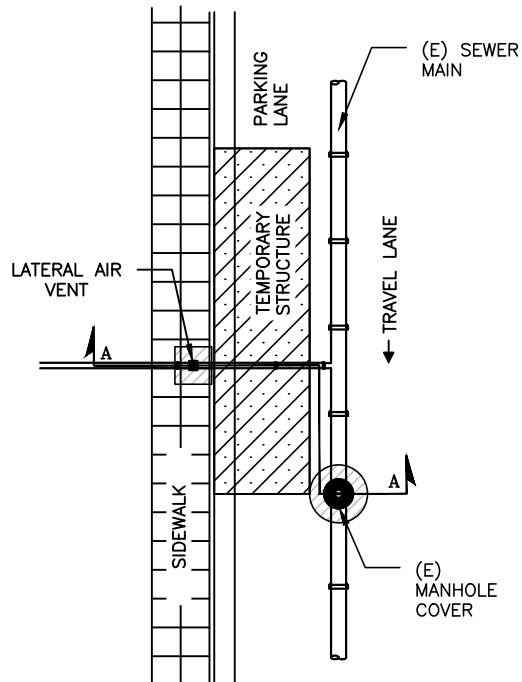

- PLAN VIEW  
- N.T.S.

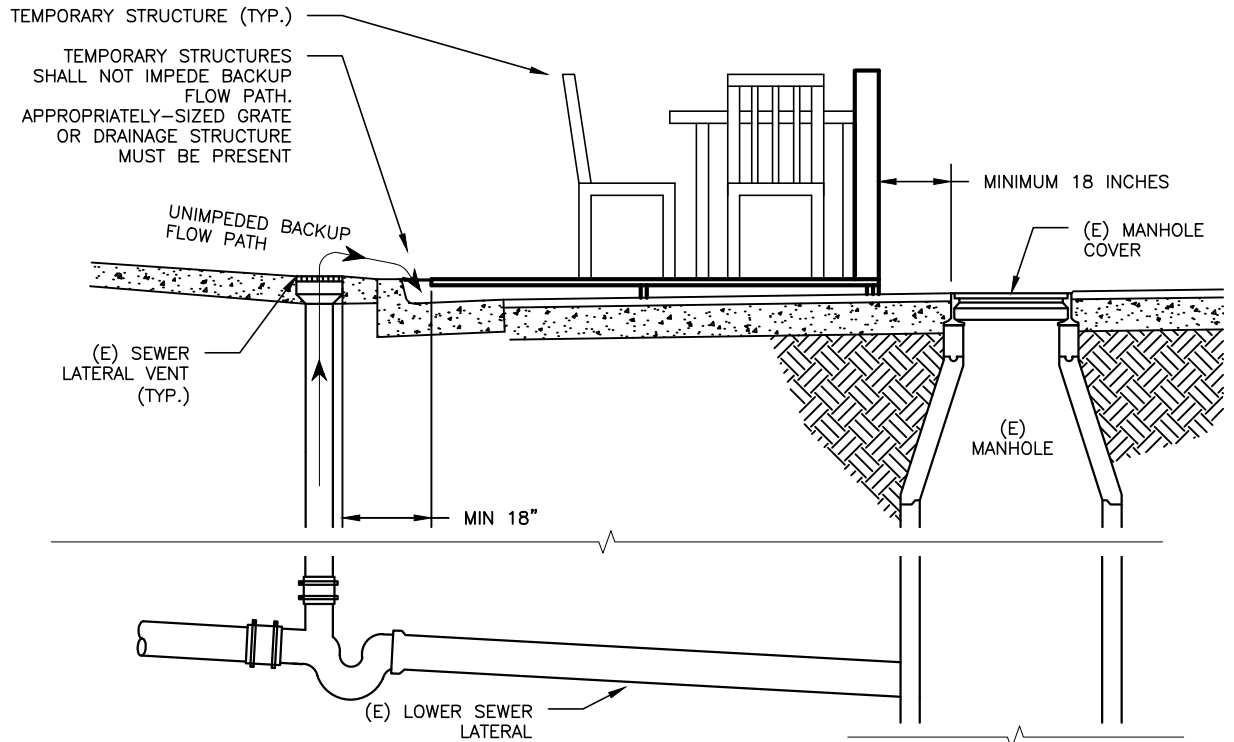

A PROFILE VIEW  
- N.T.S.

**NOTE:**

REFER TO SFPUC STANDARD APS S8 FOR FULL TEXT OF REQUIREMENTS



**San Francisco  
Water Power Sewer**  
Services of the San Francisco Public Utilities Commission

DATE 05/01/2017

SCALE N.T.S.

REV.

0

SFPUC STANDARDS FOR THE PROTECTION OF WATER AND WASTEWATER ASSETS

**MINIMUM CLEARANCE  
FROM TEMPORARY  
STRUCTURES TO  
EXISTING WASTEWATER  
ASSETS**

DWG #  
**APS S8.2**

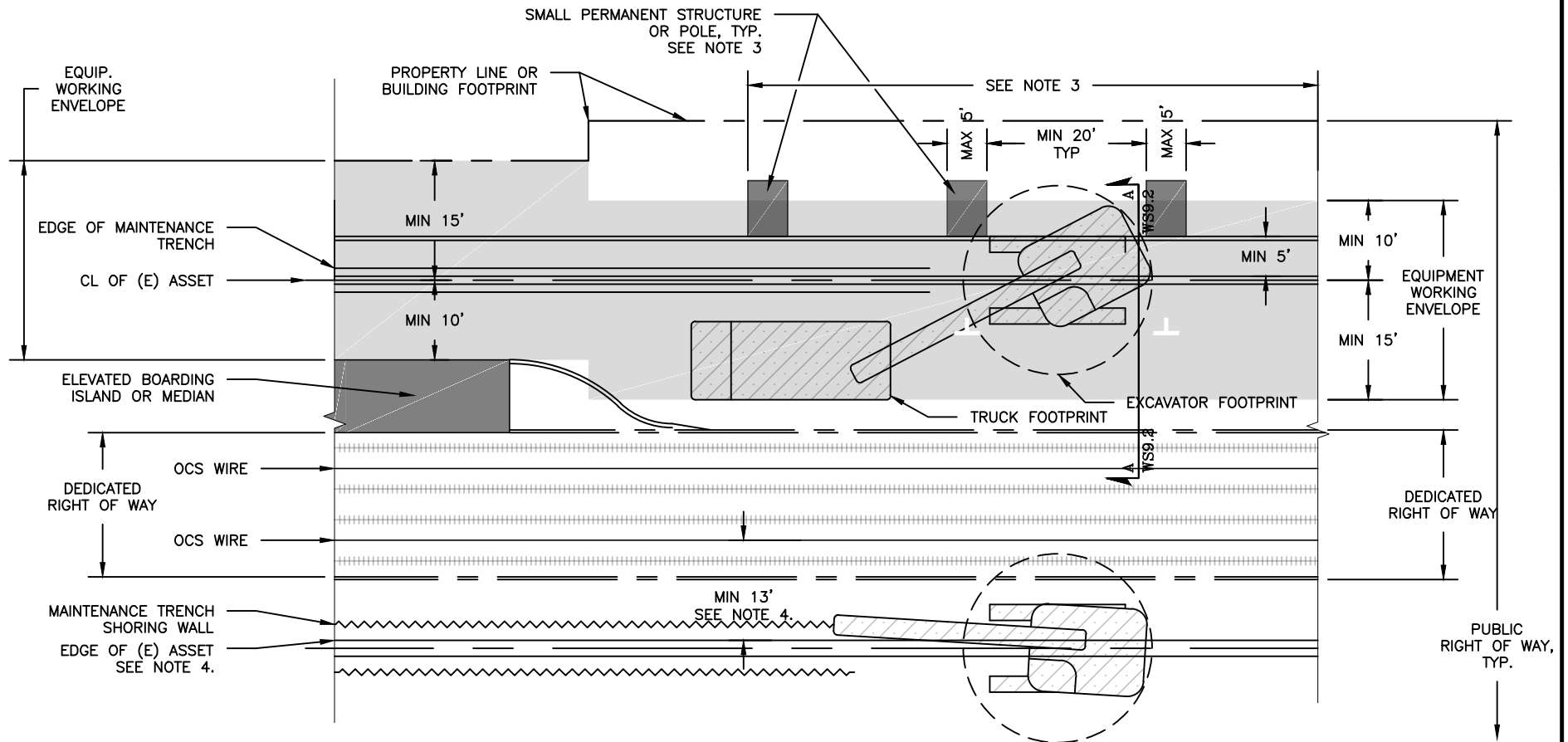

**NOTES:**

- 1. REFER TO SFPUC STANDARD APS W9 AND S9 FOR FULL TEXT OF REQUIREMENTS.
- 2 SFPUC MAY REQUIRE ADDITIONAL CLEARANCE FOR LARGE DIAMETER ASSETS THAT REQUIRE MORE EXTENSIVE SHORING.

3. PER APS W9.A.II AND APS S9.A.II, PERMANENT STRUCTURES WITH A DIMENSION OF FIVE (5) FEET OR SMALLER AS MEASURED PARALLEL TO AN SFPUC ASSET ARE PERMITTED WITHIN THE EQUIPMENT STAGING AREA, BUT SHALL NOT BE LOCATED WITHIN FIVE (5) HORIZONTAL FEET OF THE OUTSIDE EDGE OF THE SFPUC ASSET OR TWENTY (20) HORIZONTAL FEET OF ANY ADJACENT PERMANENT STRUCTURE.

4. OCS LINES SERVICING DEDICATED RIGHT OF WAYS SHALL BE LOCATED A MINIMUM OF THIRTEEN (13) HORIZONTAL FEET FROM THE OUTSIDE EDGE OF THE ASSET (W9.B AND S9.B)



**San Francisco  
Water Power Sewer**  
Services of the San Francisco Public Utilities Commission

DATE 05/01/2017

SCALE N.T.S

REV.

0

SFPUC STANDARDS FOR THE PROTECTION OF WATER AND WASTEWATER ASSETS

**MINIMUM CLEARANCE FROM PERMANENT STRUCTURES TO EXISTING SFPUC ASSETS (PLAN)**

DWG #  
**APS WS9.1**



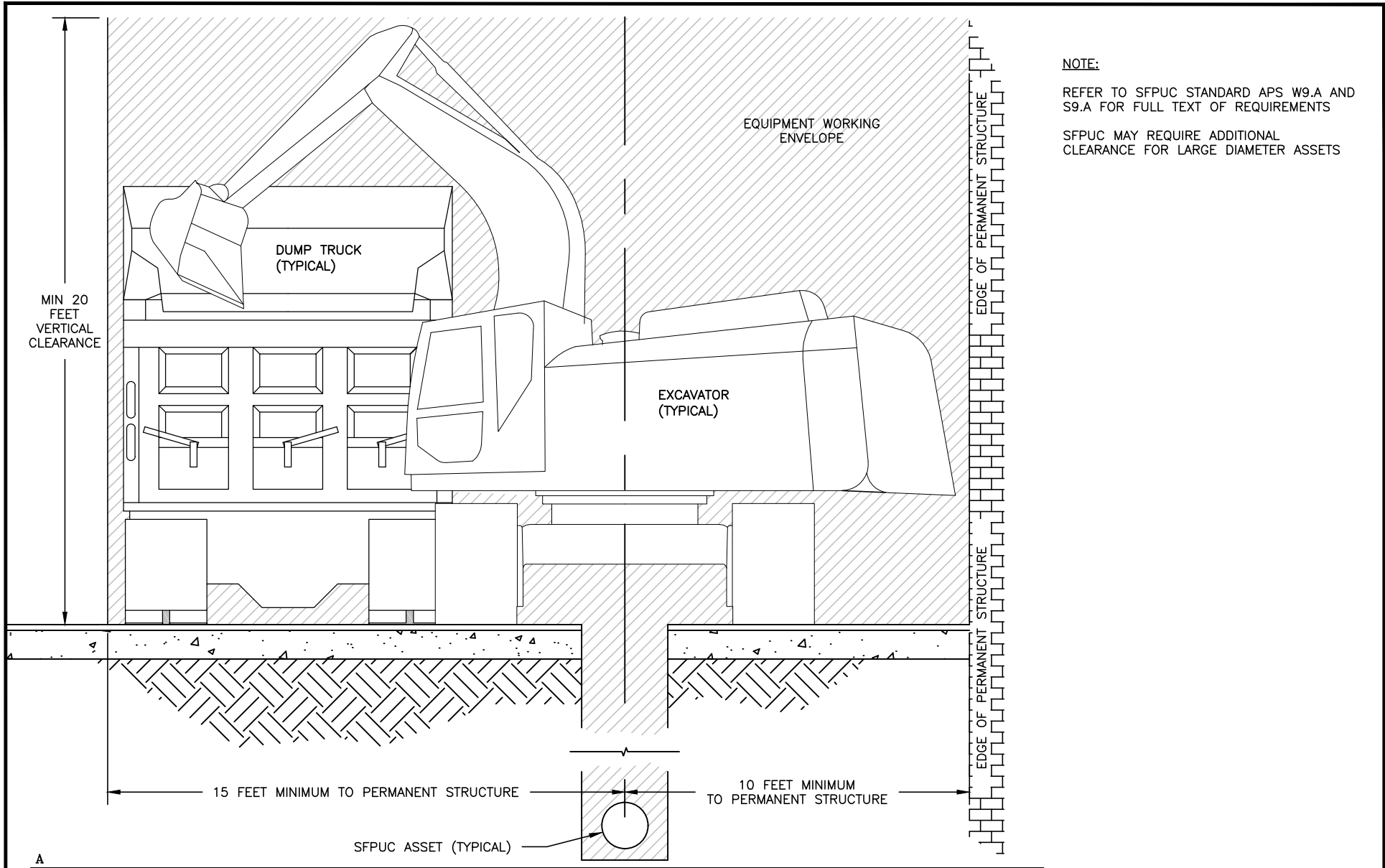

**NOTE:**

REFER TO SFPUC STANDARD APS W9.A AND S9.A FOR FULL TEXT OF REQUIREMENTS

SFPUC MAY REQUIRE ADDITIONAL CLEARANCE FOR LARGE DIAMETER ASSETS

A  
APS WS 9.1



**San Francisco  
Water Power Sewer**  
Services of the San Francisco Public Utilities Commission

DATE 05/01/2017

SCALE N.T.S

REV.

0

SFPUC STANDARDS FOR THE  
PROTECTION OF WATER AND  
WASTEWATER ASSETS

**MINIMUM CLEARANCE  
FROM PERMANENT  
STRUCTURES TO EXISTING  
SFPUC ASSETS (PROFILE)**

DWG #  
**APS WS9.2**

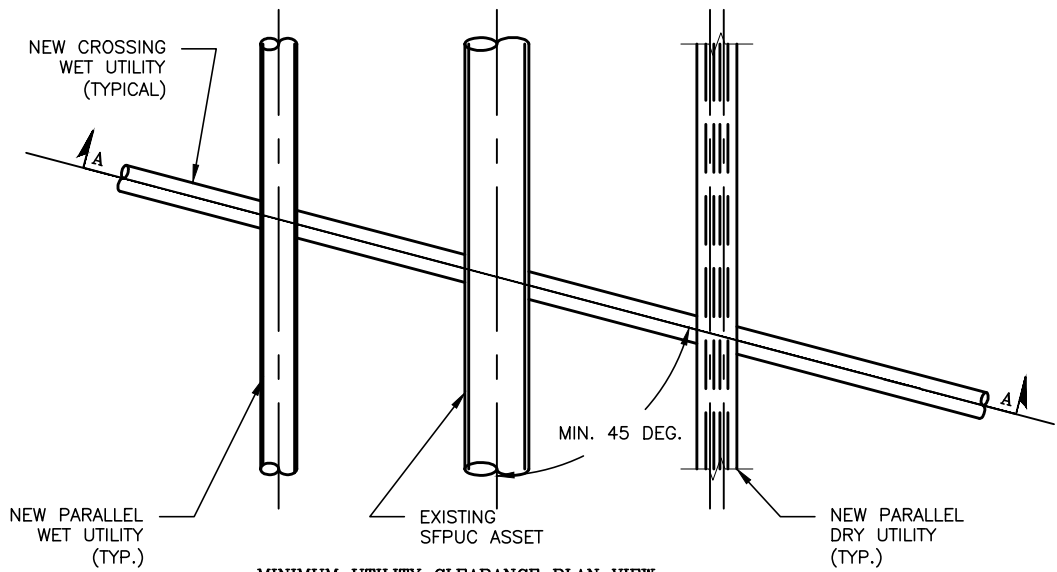

- MINIMUM UTILITY CLEARANCE PLAN VIEW  
- N.T.S.

DIM	DESCRIPTION	MINIMUM CLEARANCE
D1	MINIMUM OFFSET CLEARANCE BETWEEN OUTSIDE DIAMETER OF EXISTING SFPUC ASSET AND NEW PARALLEL UNDERGROUND UTILITY	WATER: 3 FEET
		WASTEWATER: 3.5 FEET
D2	MINIMUM CLEARANCE BETWEEN OUTSIDE DIAMETER OF EXISTING SFPUC ASSET AND NEW CROSSING UNDERGROUND UTILITY (CROSSING MAY BE ABOVE OR BELOW EXISTING SFPUC ASSET)	12 INCHES

NOTES:  
 THE MINIMUM ANGLE BETWEEN THE CENTERLINE OF AN EXISTING SFPUC ASSET AND CROSSING UNDERGROUND UTILITY SHALL BE 45 DEGREES.  
 REFER TO SFPUC STANDARD APS W10 AND S10 FOR FULL TEXT OF REQUIREMENTS.  
 NEW UTILITY INSTALLATIONS SHALL ALSO COMPLY WITH ALL OTHER APPLICABLE FEDERAL, STATE, AND LOCAL CODES, WHICH MAY BE MORE RESTRICTIVE THAN THE REQUIREMENTS SHOWN HEREIN.

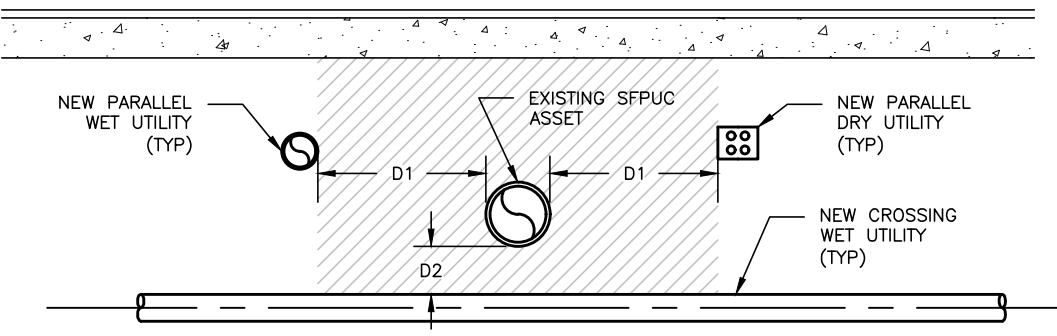

A MINIMUM UTILITY CLEARANCE PROFILE VIEW  
- N.T.S.



DATE	05/01/2017	REV.	0
SCALE	N.T.S.		

SFPUC STANDARDS FOR THE PROTECTION OF WATER AND WASTEWATER ASSETS

MINIMUM CLEARANCE FROM UNDERGROUND UTILITIES TO EXISTING SFPUC ASSETS

DWG # APS WS10.1

This page intentionally left blank.



FRONT

FRONT

NO  
TURNS

F MARKET CASTRO

SAN DIEGO

EL SE 300



San Francisco  
**Water  
Power  
Sewer**

Services of the San Francisco Public Utilities Commission